



[Creative Commons](#)

Creative Commons License Deed

Attribution-ShareAlike 3.0 Unported (CC BY-SA 3.0)

This is a human-readable summary of the [Legal Code \(the full license\)](#).
[Disclaimer](#)

You are free:

to **Share** — to copy, distribute and transmit the work

to **Remix** — to adapt the work

to make commercial use of the work



Under the following conditions:



Attribution — You must attribute the work in the manner specified by the author or licensor (but not in any way that suggests that they endorse you or your use of the work).



Share Alike — If you alter, transform, or build upon this work, you may distribute the resulting work only under the same or similar license to this one.

With the understanding that:

Waiver — Any of the above conditions can be [waived](#) if you get permission from the copyright holder.

Public Domain — Where the work or any of its elements is in the [public domain](#) under applicable law, that status is in no way affected by the license.

Other Rights — In no way are any of the following rights affected by the license:

- ◊ Your fair dealing or [fair use](#) rights, or other applicable copyright exceptions and limitations;
 - ◊ The author's [moral](#) rights;
 - ◊ Rights other persons may have either in the work itself or in how the work is used, such as [publicity](#) or privacy rights.
- **Notice** — For any reuse or distribution, you must make clear to others the license terms of this work. The best way to do this is with a link to this web page.

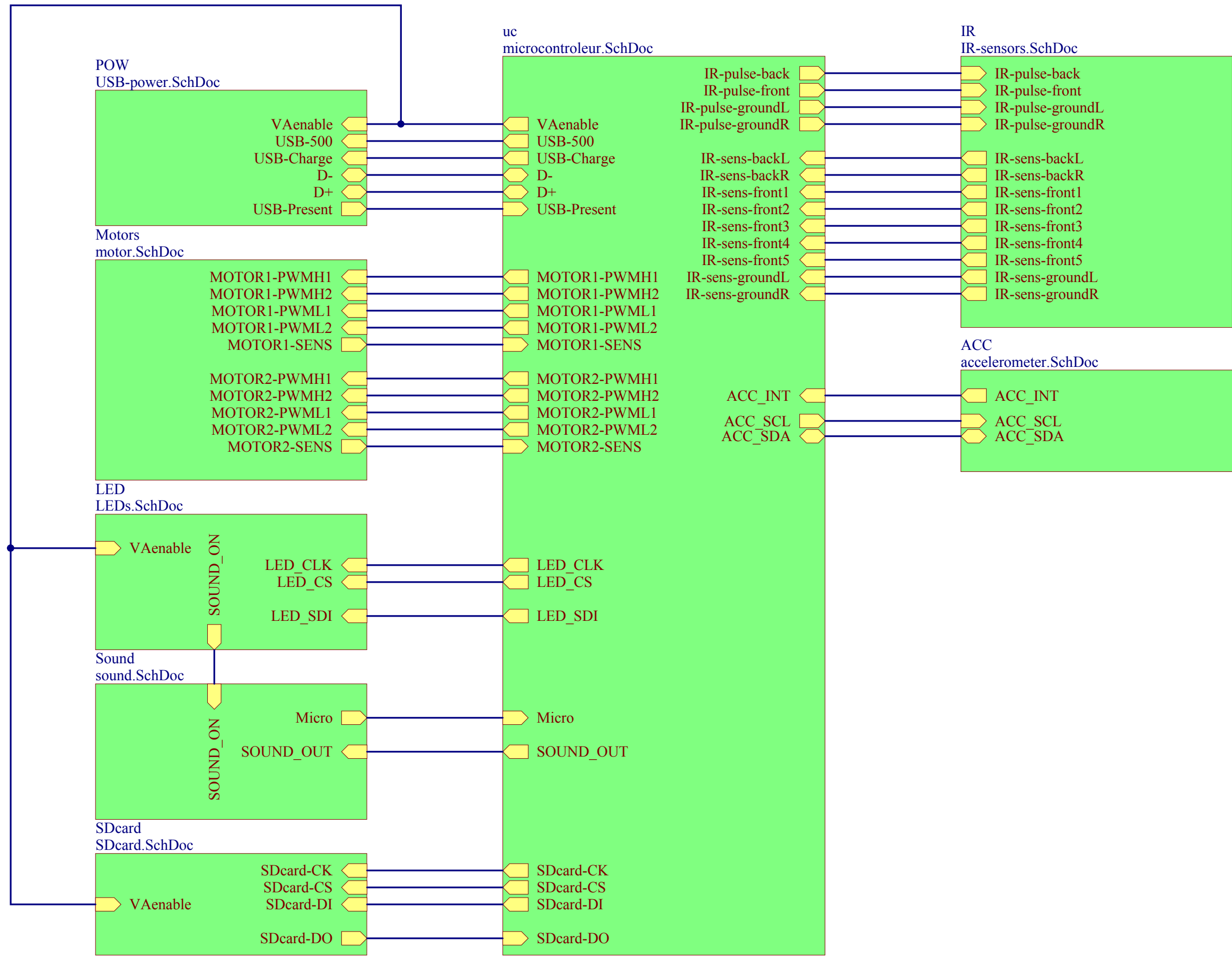

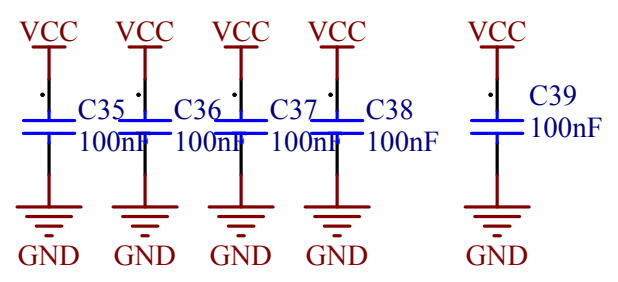
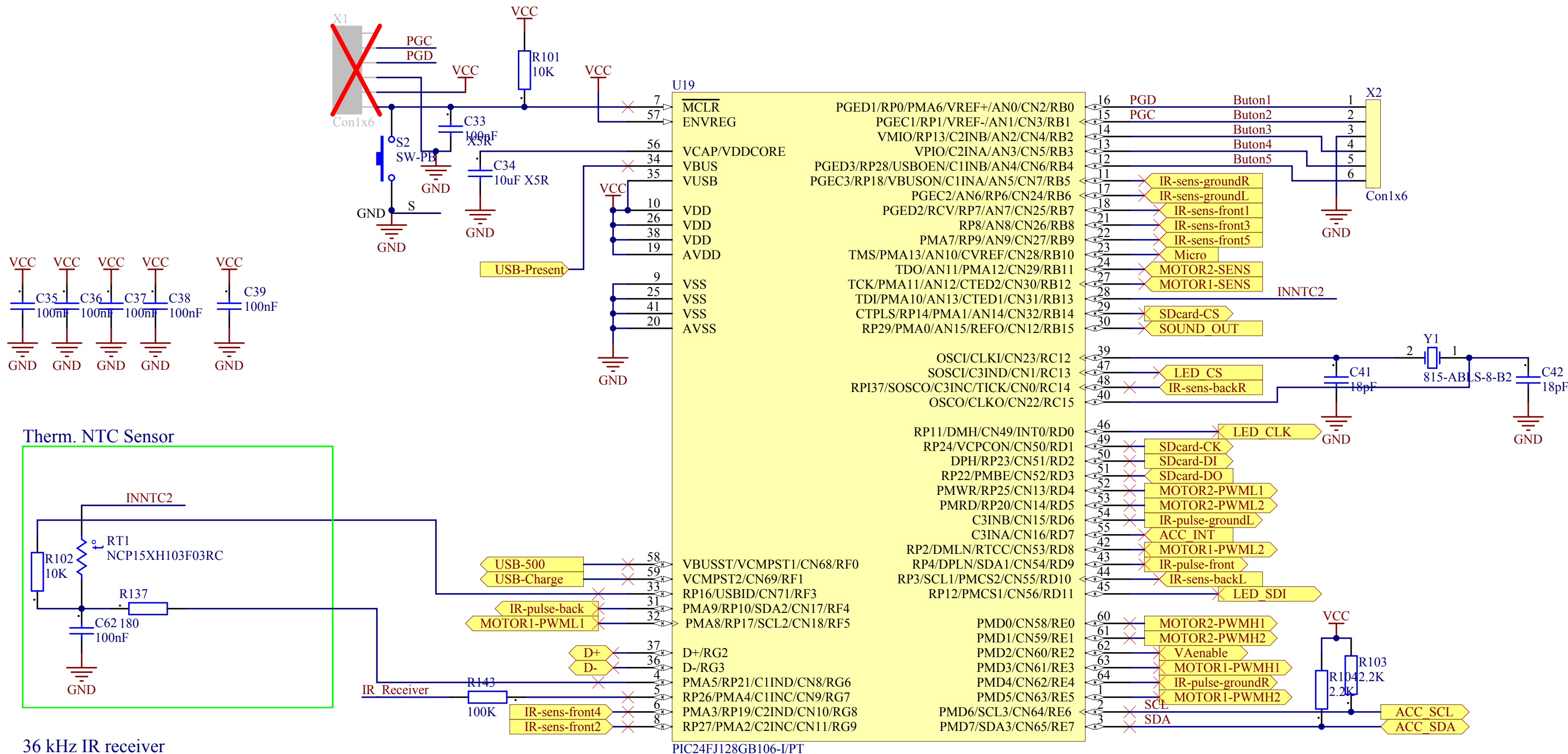

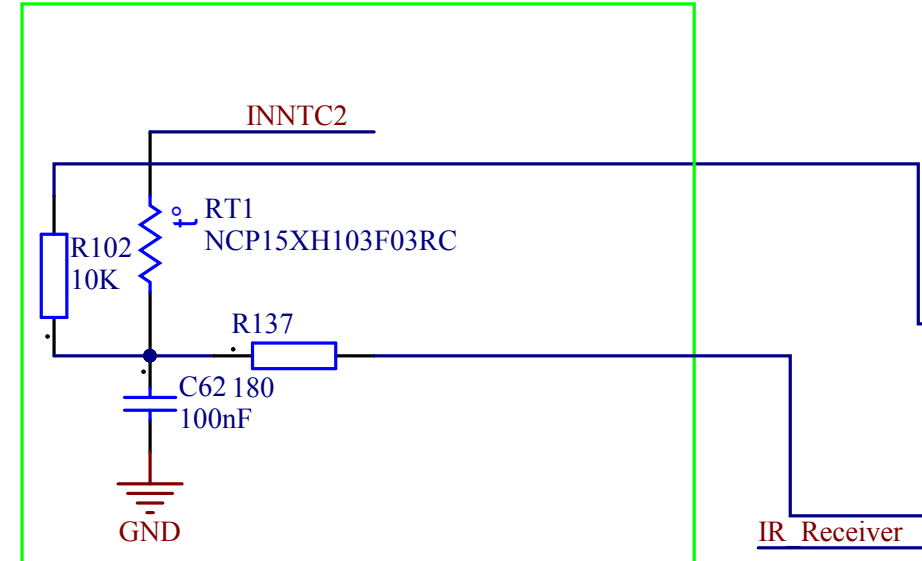

Therm. NTC Sensor

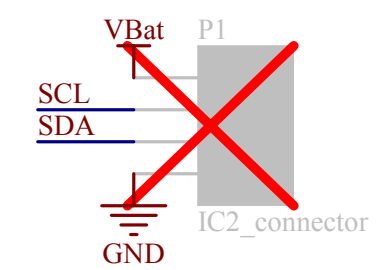
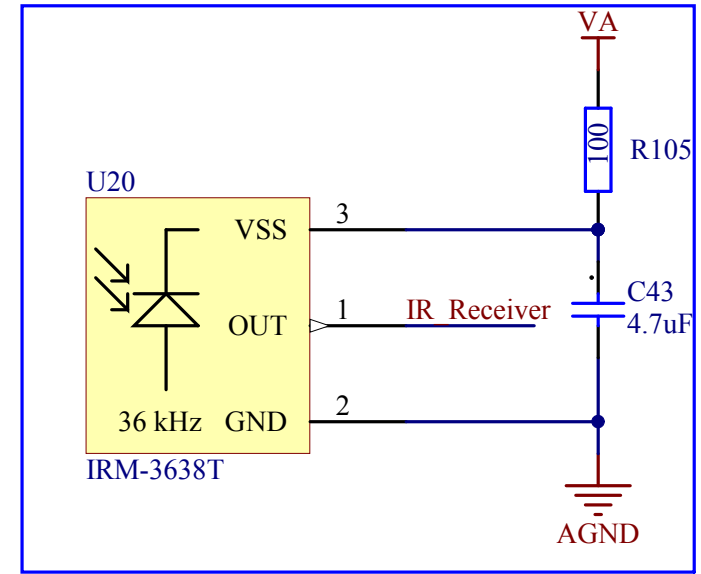

36 kHz IR receiver



Project	thymio2-main.PrjPCB	Date:	28.03.2014 14:46:50	Michael Bonani STI-IMT-LSRO1 EPFL CH-1015 LAUSANNE	 ÉCOLE POLYTECHNIQUE FÉDÉRALE DE LAUSANNE Laboratoire de Systèmes Robotiques
Part	Thymio2 PCB principal	Revision:	1.6		
File :	microcontroleur.SchDoc	Page	2 de 9		

Power good (on when power on plug) no led
 stat1 when charging red led
 stat2 when charge finished green led
 VPCC limit at 4.55V

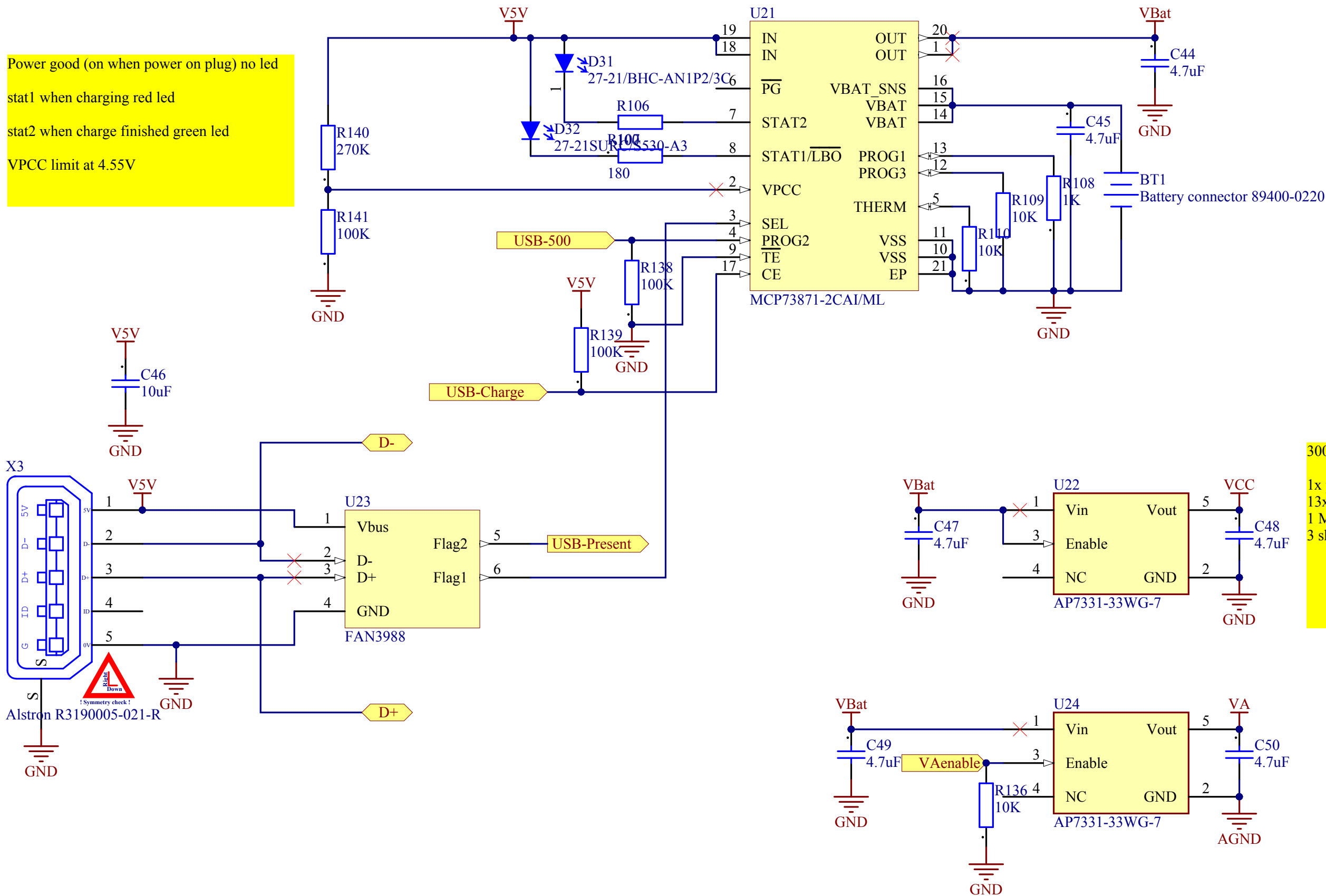

300ma max
 1x pic24F = 24 mA
 13x led 20mA = 260mA
 1 MMA7660 = 47uA
 3 shift register 160uA = 0.48mA

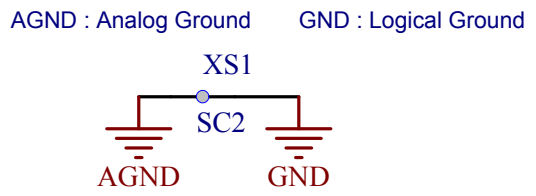

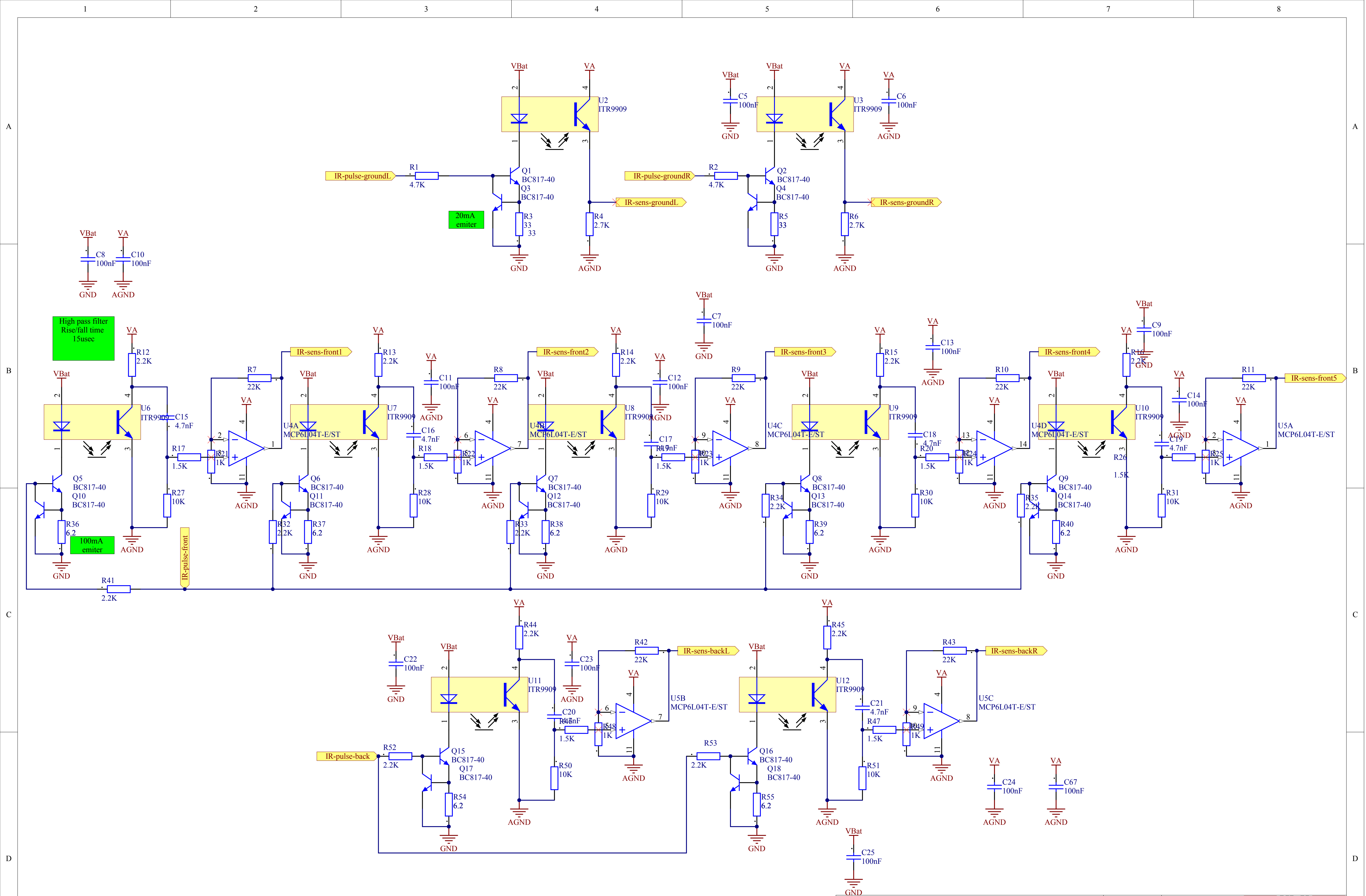

Project **thymio2-main.PrjPCB**

Part **Thymio2
PCB principal**

File: **IR-sensors.SchDoc**

Date: 28.03.2014
14:46:51
Revision: 1.6
Page 4 de 9

Michael Bonani
STI-IMT-LSROI
EPFL
CH-1015 LAUSANNE
ÉCOLE POLYTECHNIQUE
FÉDÉRALE DE LAUSANNE
Laboratoire de Systèmes Robotiques



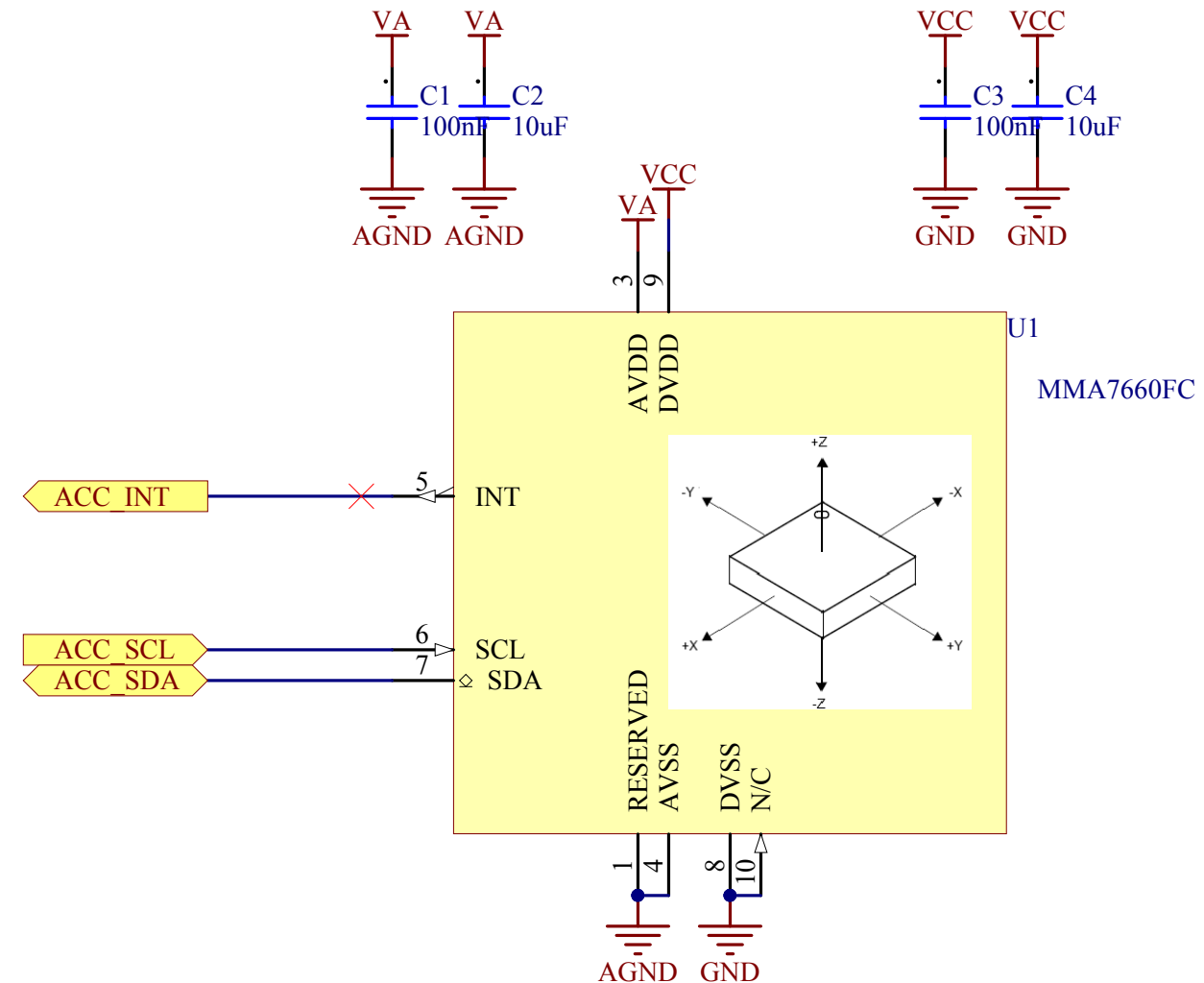

Project **thymio2-main.PrjPCB**
 Part **Thymio2 PCB principal**
 File : **accelerometer.SchDoc**

Date: 28.03.2014 14:46:52
 Revision: 1.6
 Page 5 de 9

Michael Bonani
 STI-IMT-LSRO1
 EPFL
 CH-1015 LAUSANNE
 ÉCOLE POLYTECHNIQUE FÉDÉRALE DE LAUSANNE
 Laboratoire de Systèmes Robotiques



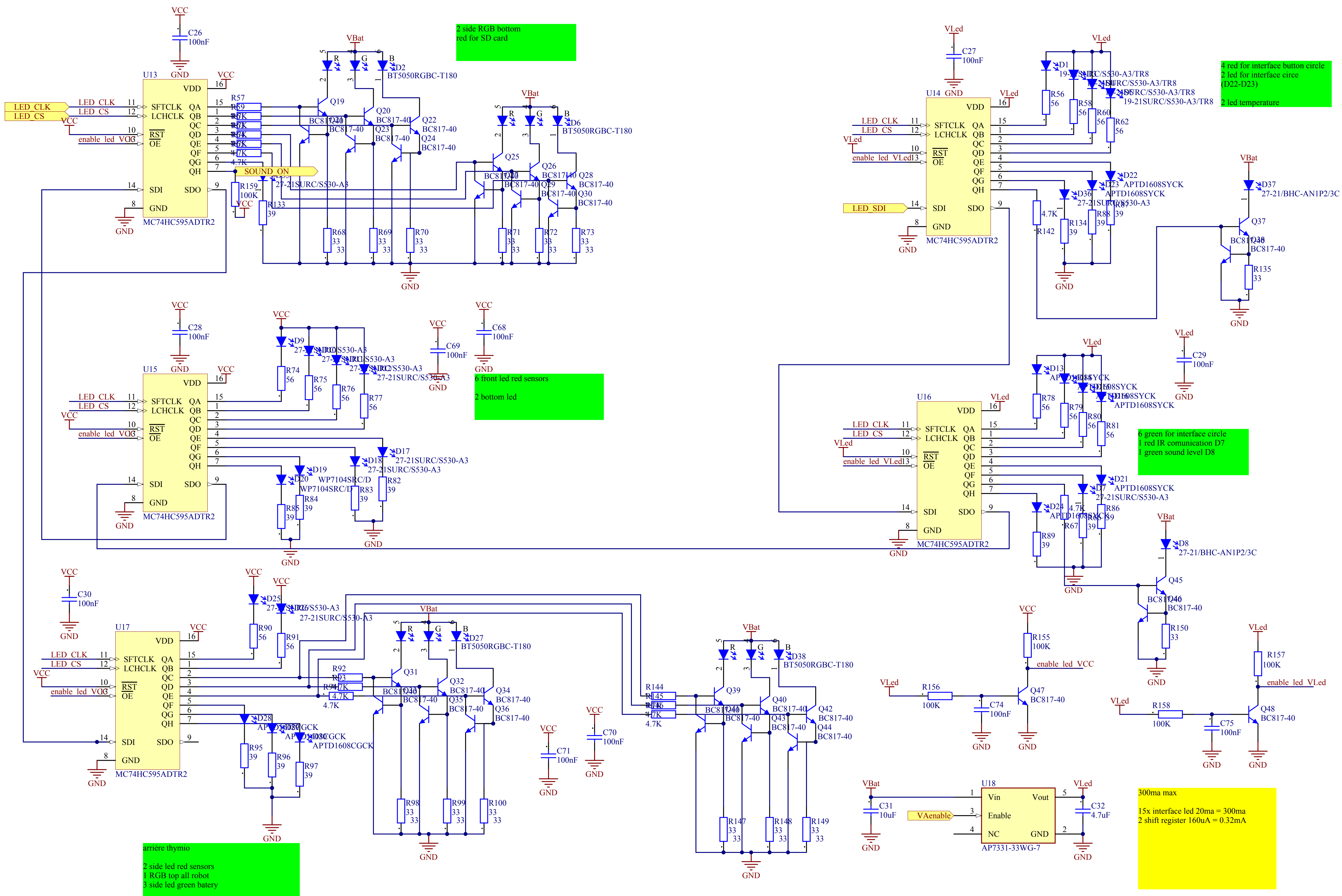

Motor Right

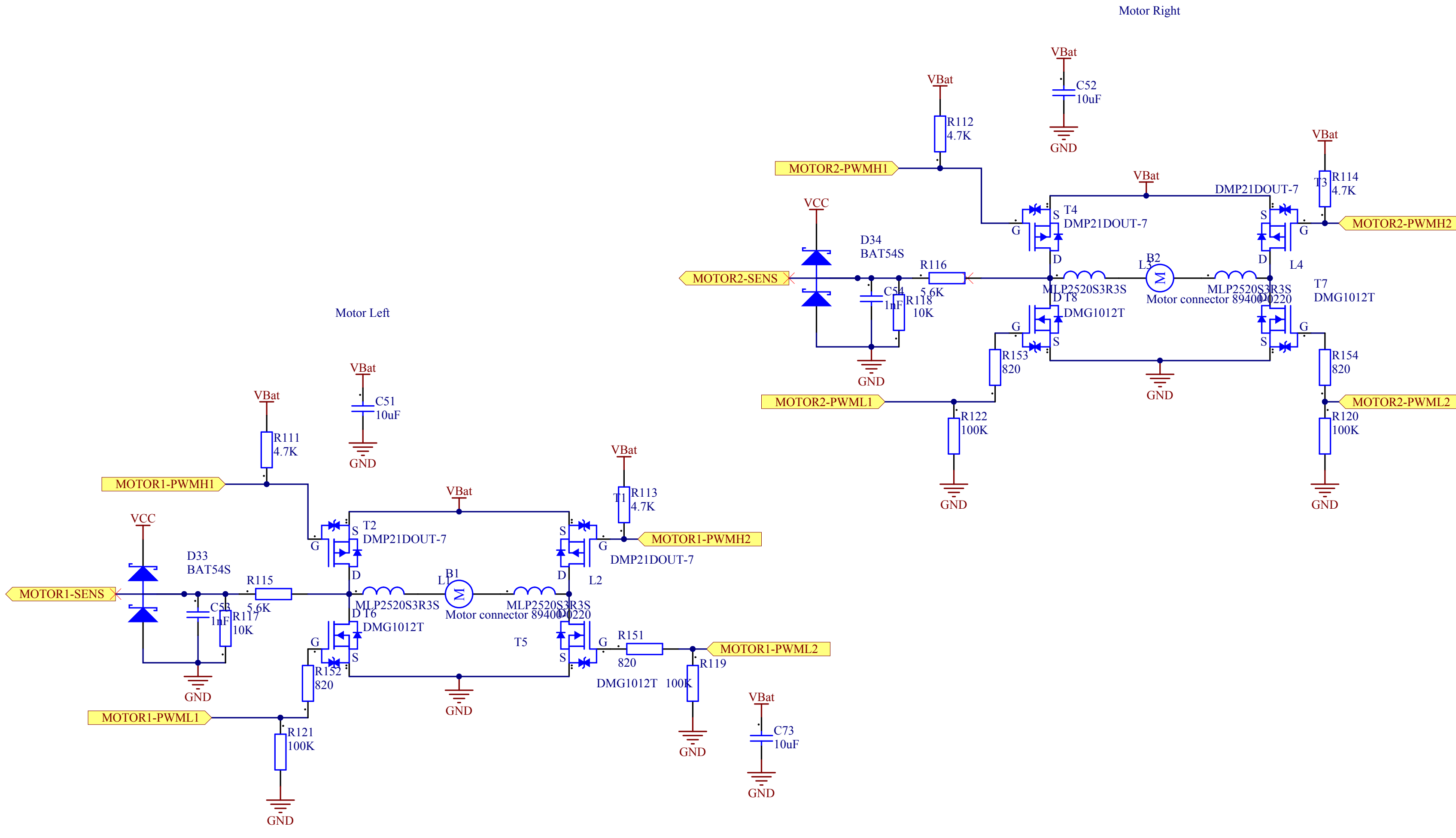

Project	<i>thymio2-main.PrjPCB</i>	Date:	28.03.2014 14:46:53	Michael Bonani STI-IMT-LSROI EPFL CH-1015 LAUSANNE	 ÉCOLE POLYTECHNIQUE FÉDÉRALE DE LAUSANNE Laboratoire de Systèmes Robotiques
Part	<i>Thymio2 PCB principal</i>	Revision:	1.6		
File :	<i>motor.SchDoc</i>	Page	7 de 9		

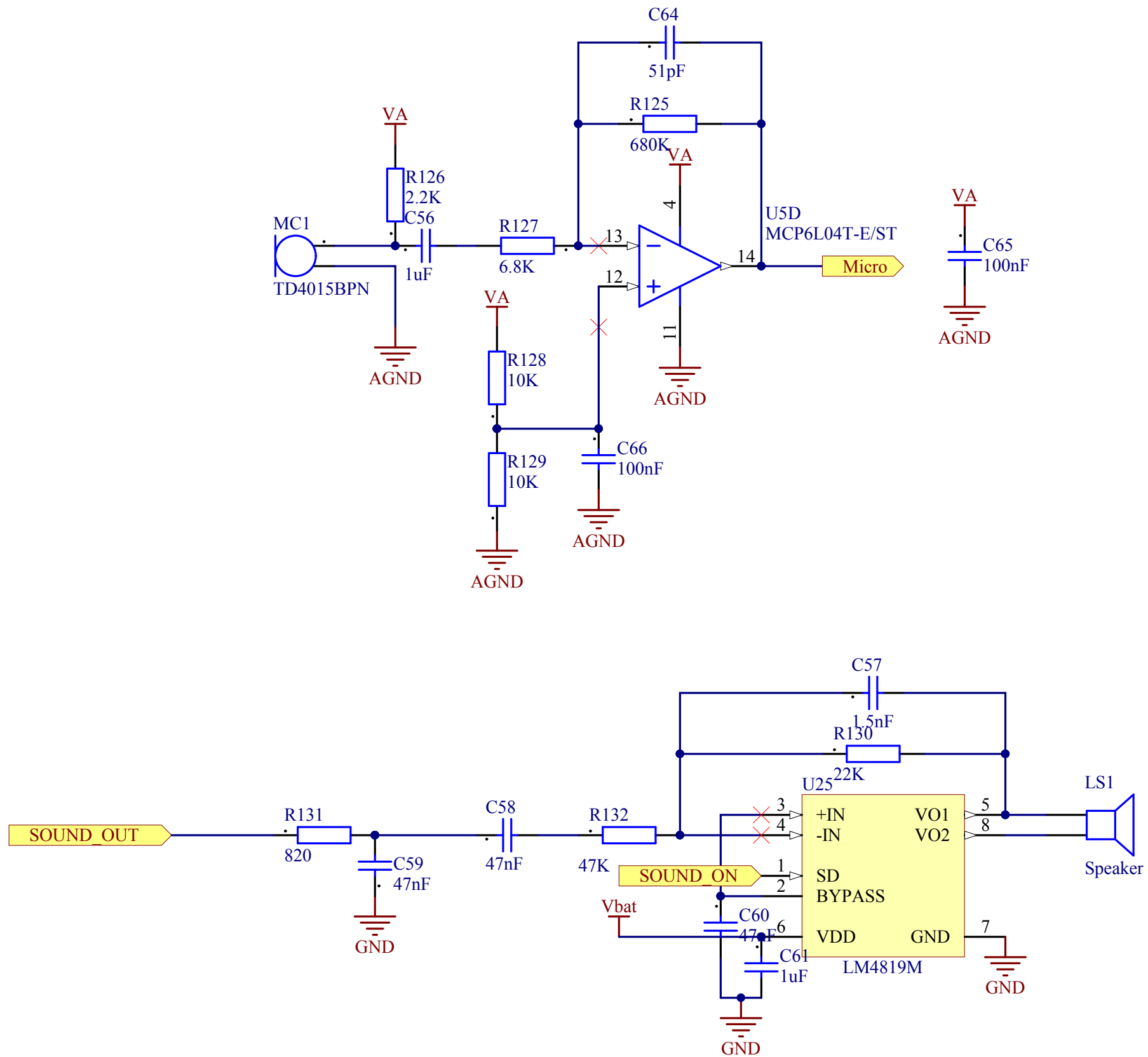

Project <i>thymio2-main.PrjPCB</i>	Date: 28.03.2014 14:46:54	Michael Bonani STI-IMT-LSRO1 EPFL CH-1015 LAUSANNE
Part <i>Thymio2 PCB principal</i>	Revision: 1.6	ÉCOLE POLYTECHNIQUE FÉDÉRALE DE LAUSANNE
File : <i>sound.SchDoc</i>	Page 8 de 9	Laboratoire de Systèmes Robotiques

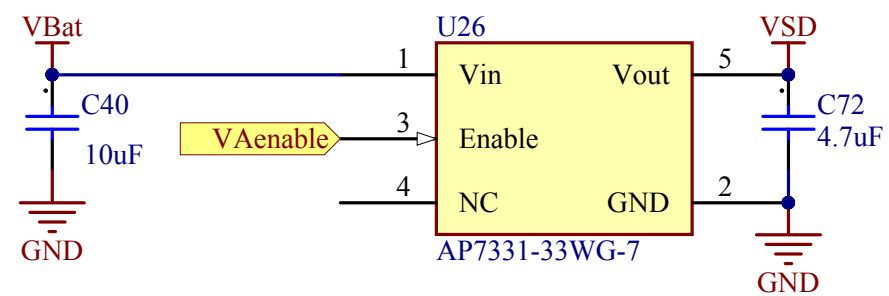
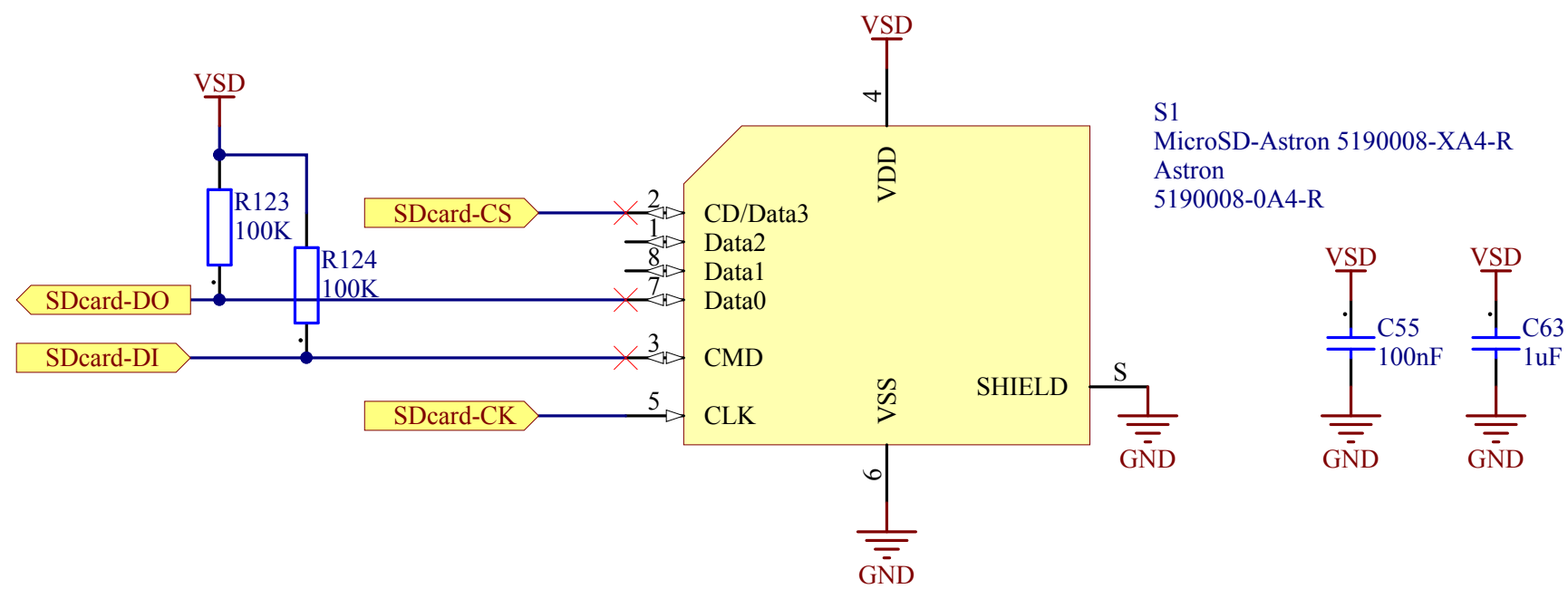

Project *thymio2-main.PrjPCB*

Part *Thymio2
PCB principal*

File : *SDcard.SchDoc*

Date:
28.03.2014
14:46:54

Revision: 1.6

Page 9 de 9

*Michael Bonani
STI-IMT-LSRO1
EPFL
CH-1015 LAUSANNE*



ÉCOLE POLYTECHNIQUE
FÉDÉRALE DE LAUSANNE

Laboratoire de Systèmes Robotiques

Quantity	Comment	Designator	Description	Footprint
2	Motor connector 89400-0220	B1, B2	Motor, General Kind	BAT-2
1	Battery connector 89400-0220	BT1	Multicell Battery	BAT-2
38	100nF	C1, C3, C5, C6, C7, C8, C9, C10, C11, C12, C13, C14, C22, C23, C24, C25, C26, C27, C28, C29, C30, C33, C35, C36, C37, C38, C39, C55, C62, C65, C66, C67, C68, C69, C70, C71, C74, C75	Capacitor	CAPC1608X08L
8	10uF	C2, C4, C31, C40, C46, C51, C52, C73	Capacitor	CAPC1608X08L
7	4.7nF	C15, C16, C17, C18, C19, C20, C21	Capacitor	CAPC1608X08L
9	4.7uF	C32, C43, C44, C45, C47, C48, C49, C50, C72	Capacitor	CAPC1608X08L
1	10uF X5R	C34	Capacitor	CAPC1608X08L
2	18pF	C41, C42		CAPC1608X08L
2	1nF	C53, C54	Capacitor	CAPC1608X08L
3	1uF	C56, C61, C63	Capacitor	CAPC1608X08L
1	1.5nF	C57	Capacitor	CAPC1608X08L
3	47nF	C58, C59, C60	Capacitor	CAPC1608X08L
1	51pF	C64	Capacitor	CAPC1608X08L
4	19-21SURC/S530-A3/TR8	D1, D3, D4, D5	SMD Red 0603 2V@20ma 56 mcd	DIOC1608X08N
4	BT5050RGB-C-T180	D2, D6, D27, D38	\$0.027/2000K	LEDSMD5
12	27-21SURC/S530-A3	D7, D9, D10, D11, D12, D17, D18, D25, D26, D32, D35, D36	SMD Red led right angle mount 2V@20ma 57mcd	27-21 EVERLIGHT
3	27-21/BHC-AN1P2/3C	D8, D31, D37	SMD Blue led right angle mount 3.3V@20ma 28mcd	27-21 Everlight Blue
8	APTDL608SYCK	D13, D14, D15, D16, D21, D22, D23, D24	LED standard - CMS Helios SMD Yellow 590nm 480mcd	DIOC1608X08N
2	WP7104SRC/D	D19, D20	Red led 2V@20ma 57mcd	LED_TH_3MM_20MM
3	APTDL608CGCK	D28, D29, D30	LED standard - CMS Helios SMD Green 570nm 230mcd	DIOC1608X08N
2	BAT545	D33, D34	Schottky Barrier Double Diode	SOT23_N
4	MPL2520S3R3S	L1, L2, L3, L4	Inductors for Power Circuits Multilayer/STD Magnetic Shielded	INDC2520X12L
1	Speaker	LS1	Loudspeaker	PN2
1	TD4015BPN	MC1	Omnidirectional Back Electret Condenser Microphone	MICRO_TD4015BPN
48	BC817-40	Q1, Q2, Q3, Q4, Q5, Q6, Q7, Q8, Q9, Q10, Q11, Q12, Q13, Q14, Q15, Q16, Q17, Q18, Q19, Q20, Q21, Q22, Q23, Q24, Q25, Q26, Q27, Q28, Q29, Q30, Q31, Q32, Q33, Q34, Q35, Q36, Q37, Q38, Q39, Q40, Q41, Q42, Q43, Q44, Q45, Q46, Q47, Q48	NPN General-purpose Transistor	SOT23_N
20	4.7K	R1, R2, R57, R59, R61, R63, R64, R65, R67, R92, R93, R94, R111, R112, R113, R114, R142, R144, R145, R146	Resistor	RESC1608X06L
16	33	R3, R5, R68, R69, R70, R71, R72, R73, R98, R99, R100, R135, R147, R148, R149, R150	120, Resistor, 120, 120, 120, 120, 120, 120, 120, Resistor, 120, 120, 120, Resistor	RESC1608X06L
2	2.7K	R4, R6	Resistor	RESC1608X06L
8	22K	R7, R8, R9, R10, R11, R42, R43, R130	120, 120, 120, 120, 120, 120, Resistor	RESC1608X06L
17	2.2K	R12, R13, R14, R15, R16, R32, R33, R34, R35, R41, R44, R45, R52, R53, R103, R104, R126	120, 120, 120, 120, 120, Resistor, Resistor, Resistor, Resistor, Resistor, 120, 120, Resistor, Resistor, Resistor, Resistor, Resistor	RESC1608X06L
7	1.5K	R17, R18, R19, R20, R26, R46, R47	120	RESC1608X06L
8	1K	R21, R22, R23, R24, R25, R48, R49, R108	120, 120, 120, 120, 120, 120, Resistor	RESC1608X06L
16	10K	R27, R28, R29, R30, R31, R50, R51, R101, R102, R109, R110, R117, R118, R128, R129, R136	120, 120, 120, 120, 120, 120, 120, Resistor, Resistor, Resistor, Resistor, Resistor, Resistor, Resistor, Resistor, Resistor	RESC1608X06L
7	6.2	R36, R37, R38, R39, R40, R54, R55	120	RESC1608X06L
14	56	R56, R58, R60, R62, R74, R75, R76, R77, R78, R79, R80, R81, R90, R91	Resistor	RESC1608X06L
14	39	R66, R82, R83, R84, R85, R86, R87, R88, R89, R95, R96, R97, R133, R134	Resistor	RESC1608X06L
2	100	R105, R106	Resistance	RESC1608X06N
2	180	R107, R137	Resistor	RESC1608X06L
2	5.6K	R115, R116	Resistor	RESC1608X06L
15	100K	R119, R120, R121, R122, R123, R124, R138, R139, R141, R143, R155, R156, R157, R158, R159	Resistor	RESC1608X06L
1	680K	R125	Resistor	RESC1608X06L
1	6.8K	R127	Resistor	RESC1608X06L
5	820	R131, R151, R152, R153, R154	Resistor	RESC1608X06L
1	47K	R132	Resistor	RESC1608X06L
1	270K	R140	Resistor	RESC1608X06L
1	NCP15XH103F03RC	RT1	Thermistors - NTC 10K OHM 1% 0402	RESC1005X04L
1	MicroSD-Astron 5190008-XA4-R	S1	MicroSD Card connector 5190008-XA4-R	Astron 5190008-XA4-R
1	SW-PB	S2	Switch	FSMRA2JH
4	DMP21DOUT-7	T1, T2, T3, T4	Transistor MOSFET 1 x P Pining : 1=G, 2=S, 3=D	SOT50P160X80-3N
4	DMG1012T	T5, T6, T7, T8	Transistor MOSFET 1 x N, Pining : 1=G, 2=S, 3=D	SOT50P160X80-3N
1	MMA7660FC	U1	MMA7660FC: XYZ-AXIS ACCELEROMETER ±1.5 g	DFN50P300X300X100-12N
2	ITR9909	U2, U3	Everlight Opto Interrupter	ITR9909_LONG
2	MCP6L04T-E/ST	U4, U5	1 MHz, 85 µA Quad Op Amp, 14-Pin TSSOP, Extended Temperature Range, Tape and Reel	TSSOP-ST14_N
7	ITR9909	U6, U7, U8, U9, U10, U11, U12	Everlight Opto Interrupter	ITR9909_EDGE
5	MC74HC595ADTR2	U13, U14, U15, U16, U17	8-Bit Serial-Input/Serial or Prallel-Output Shift Register with Latched 3-State Outputs	948F-01_N
4	AP7331-33WG-7	U18, U22, U24, U26	300mA, Low Quiescent Current, Fast Transient LDO	SOT95P285X100-5N
1	PIC24FJ128GB106-U/PT	U19	General Purpose 16-Bit Flash Microcontroller with USB On-The-Go, 128KB Flash, 16KB SRAM, 64-Pin TQFP, Industrial Temperature	TQFP-PT64_N
1	IRM-3638T	U20	IR Receiver Module (38 kHz) for Remote Control Systems	IR-receiver
1	MCP73871-2CAJ/ML	U21	Stand-Alone System Load Sharing and Li-Ion/Li-Polymer Battery Charge Management Controller, 4.2V, 20-Pin QFN, Industrial Temperature	QFN-ML20_N
1	FAN3988	U23	USB/Charger and Over Voltage Detection Device	MLP_1.45X1MM
1	LM4819M	U25	350mW Audio Power Amplifier with Shutdown Mode	M08A_N
1	Con1x6	X2	1 x 6 pins connector	MHDR1X6
1	Alstron R3190005-021-R	X3	USB connector Micro B	ASTRON 3190005-X21-R
1	815-ABLS-8-B2	Y1	Surface Mount Quartz Crystal 8Mhz	HC49/4H_SMX

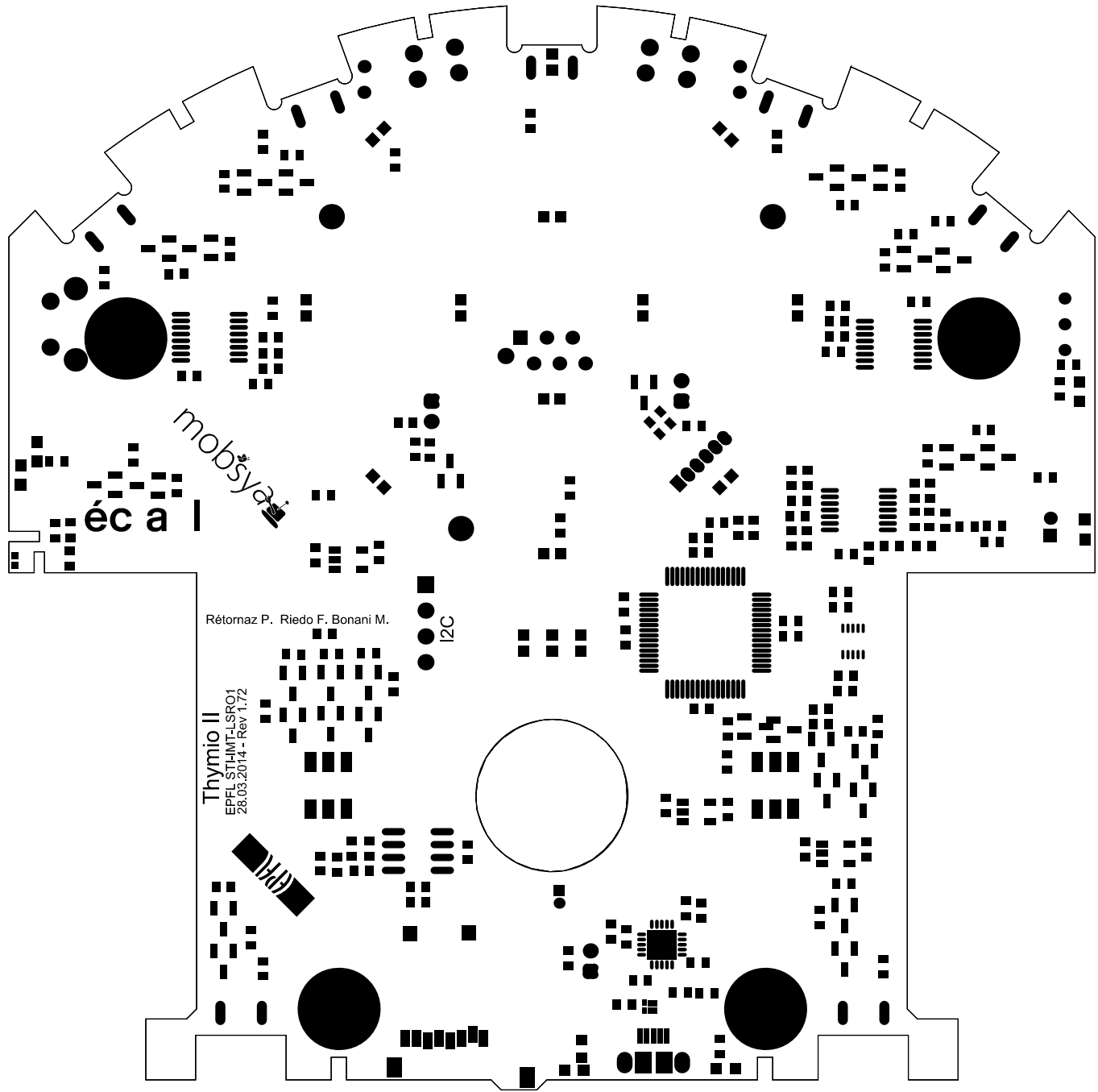

éc a I

mobsya

Rétornaz P. Riedo F. Bonani M.

12C

Thymio II

EPFL ST/IMT-LSRO1
28.03.2014 - Rev 1.72



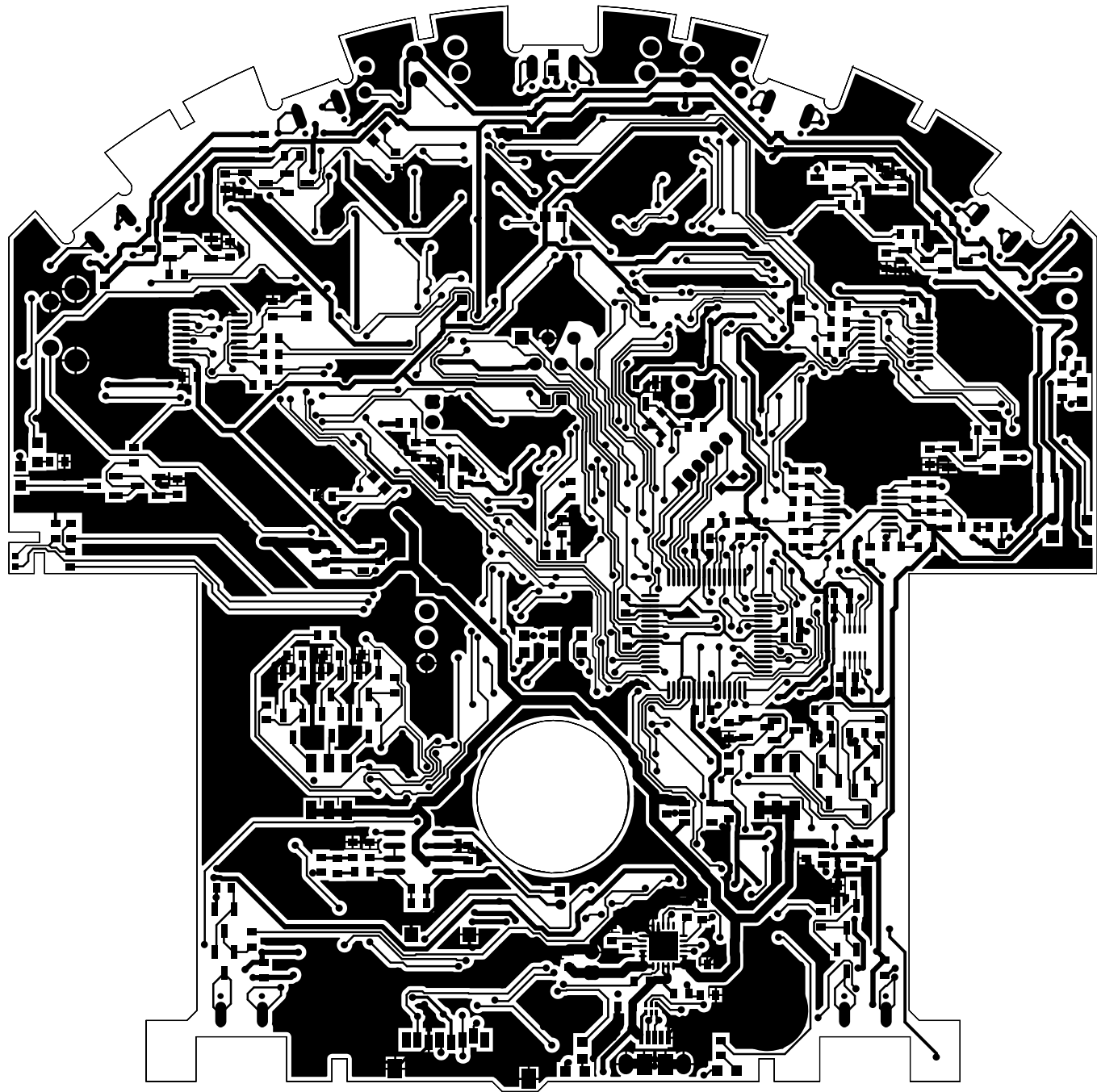

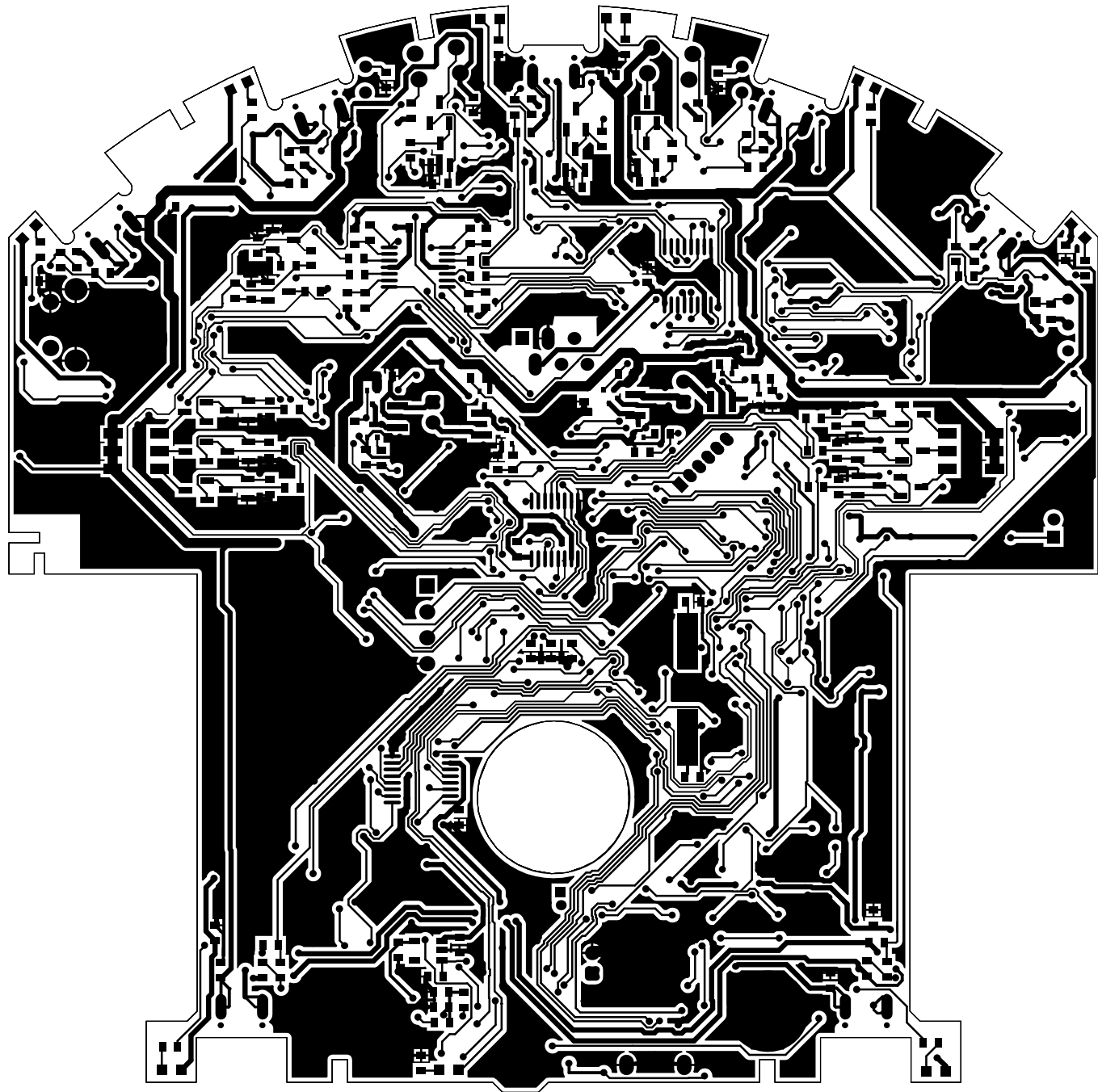

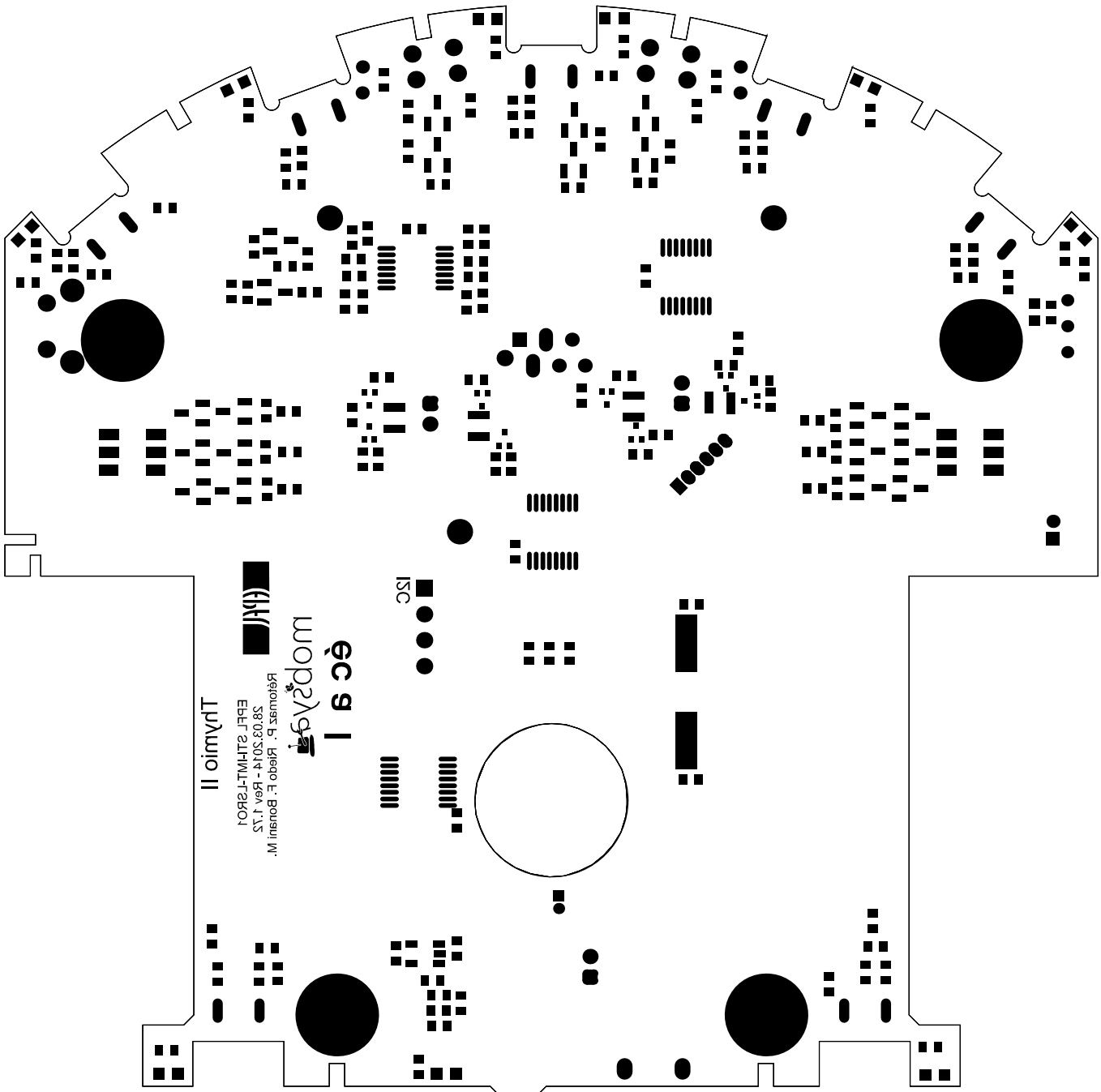

ΥΠΟΥΡΓΕΙΟ ΠΑΙΔΕΙΑΣ ΚΑΙ ΘΡΗΣΚΕΥΜΑΤΩΝ
 ΕΠΙΤΡΟΠΗ ΕΡΕΥΝΑΣ ΚΑΙ ΠΡΟΤΥΠΩΝ ΣΧΟΛΕΙΩΝ

Τμήμα II

Références : Riego, F. Boussin M.
 58.03.2014 - Rev. 1.15
 EpFL 21HML-TSR01

ISC

ΕΣ 9 I

