

# Atmel ATMega8L

## Brainboard Add-on v2.0

for the **Solarbotics SUMOVORE**

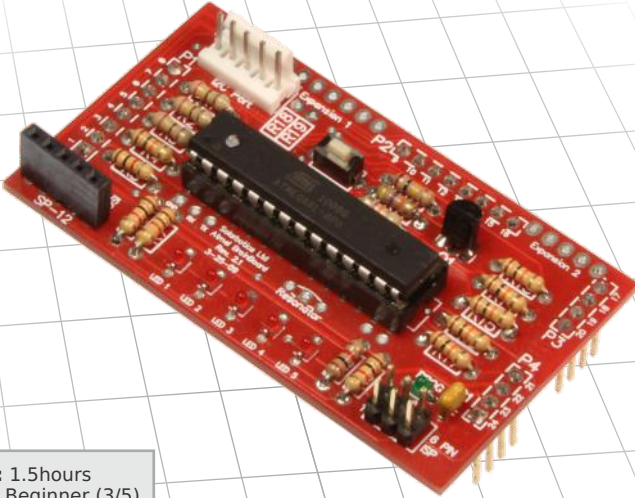

**Build Time:** 1.5hours  
**Skill Level:** Beginner (3/5)

### Ready to step up from the discrete brain on your stock Sumovore?

Here's the Atmel ATMega8L-based Brainboard to take over!

The ATmega8L is a very popular microcontroller, supported by many programming languages (some free!). Program it with a home-made parallel-port cable, or use the popular Atmel STK-500 development system. It's a fast, inexpensive, and very powerful upgrade for your Solarbotics Sumovore Robot Kit!

The new version 2 brainboard adds full I2C interface support, better programmability and the ability to add bread-board space!

(Sumovore Sumo robot kit and programmer/DB25 printer cable required)

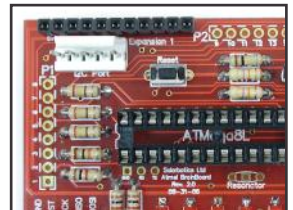
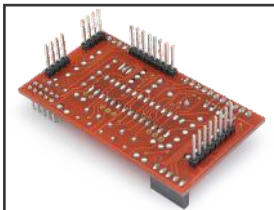
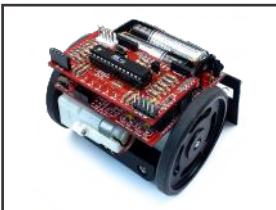

We strongly suggest you inventory the parts in your kit to make sure you have all the parts listed. Use a pen, pencil, pricked finger, chocolate bar - anything to mark off the items. If anything is missing, contact us for replacement parts information.

**Disclaimer of Liability**

Solarbotics Ltd. is not responsible for any special, incidental, or consequential damages resulting from any breach of warranty, or under any legal theory, including lost profits, downtime, good-will, damage to or replacement of equipment or property, and any costs or recovering of any material or goods associated with the assembly or use of this product. Solarbotics Ltd. reserves the right to make substitutions and changes to this product without prior notice. (Sorry, gotta make the lawyer happy!)



# The ATmega8L Brainboard

## Parts List



### ATmega8 Brainboard Components

- 1 - Printed Circuit Board (PCB)
- 1 - 0.1 $\mu$ F capacitor (labeled '104')
- 5 - Tiny red LEDs (sensor indicators)
- 1 - Tiny green LED (programming indicator)
- 1 - 2N3904 NPN Transistor
- 3 - 240 Ohm Resistors (Red/Yellow/Brown) for Positions R1, R2, R3
- 6 - 10k Resistor (Brown/Black/Orange) for Position R4, R13, R14, R15, R16, R17
- 5 - 1k Resistors (Brown/Black/Red) for Positions R5, R6, R7, R8, R9
- 1 - 100k Resistor (Brown/Black/Yellow) for Position R10
- 2 - 47k Resistors (Yellow/Violet/Orange) for Position R11, R12
- 1 - ATmega8L 28 pin Carrier
- 1 - Atmel ATmega8L Microcontroller
- 1 - Reset Button
- 1 - QRD1114 edge sensor (for Sumovore's middle sensor)
- 1 - 5-Socket programming header
- 1 - Polarized 5-Pin I2C interface header
- 1 - 6-Pin (2 rows of 3 pins) STK-500 programming header
- 1 - 5-Pin Header (for building optional programming cable)
- 2 - 4-Pin Sumovore interface headers
- 2 - 8-Pin Sumovore interface headers
- 1 - 5-Pin Low-profile Socket for Breadboard expansion board
- 1 - 11-Pin Low-profile Socket for Breadboard expansion board

### Tools Required

- Soldering equipment
- Side-cutters or fine snips
- Computer (for programming / downloading code!)

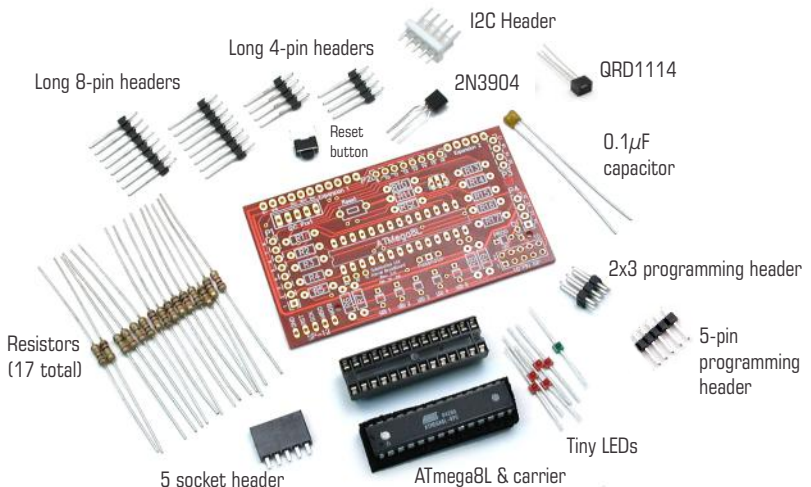



Looking for a more flexibility out of your Sumovore? Well, welcome to the next in our series of brainboards - the ATmega8L. The ATmega8L offers an impressive list of features, including (but not limited to):

- 8kB flash memory
- Three Pulse-width modulation (PWM) channels
- Six Analog-to-digital converters (ADCs)
- In-circuit programmable
- Internal RC oscillator (optional resonator needed to surpass 8MHz)
- 23 programmable Input/Output (I/O) lines
- I<sup>2</sup>C protocol for sensor networking
- Single clock execution up to 1MIPs/MHz (this means “it’s QUICK”, like 250 times faster than a standard Basic Stamp 2!)

We’ve made good use of the capabilities of the ATmega8L, but there’s lots more you can do with it, including program it with the free open-source GCC C-compiler (our weapon of choice) or other compilers for BASIC, JAL, Java, Assembler, Pascal, Forth,... it goes on and on!

This is **not** a kit for a microcontroller beginner. Anybody using this brainboard should have the appropriate skills, or be ready to learn the techniques that make a microcontroller... microcontrol!

This kit lets you swap out the default discrete brainboard for a programmable version. If you run into any problems, it’s a simple process to swap a different brain back in. We’ve had days when it’d be nice to swap in a new brain, haven’t you?

This brainboard features:

- Atmel ATmega8L microcontroller
- 5 indicator LEDs & 1 programming LED indicator
- STK500 and SP-12 programming headers
- Microprocessor Reset Switch
- Standard 0.1” expansion interface holes for breadboard add-ons
- Expansion interface featuring:
  - 5 digital / interrupt I/O (Port D 2-6, shared with LED indicators)
  - 5 analog inputs / digital I/O (Ports C 0-4, shared with line sensors)
  - I<sup>2</sup>C Bus
  - Regulated 5V and Raw 6V
  - Access to the microcontroller serial interface (level shifting req’d)



# The ATmega8L Brainboard



Building It - Steps 1, 2, 3

Remember - when you're building this kit, you must bend the resistors down right near the resistor body. This PCB is designed on the tight side, so being compact counts!

**Step 1 - 3 x 240 Ohm Resistors (Red / Yellow / Brown):** These resistors are part of the SP12 programming interface that buffer the signals. Install in positions **R1, R2, & R3**.

**Step 2 - 1 x 10k Resistor (Brown / Black / Orange):** This 10k resistor is the signal pull-up for the reset switch. Install it in position **R4**.

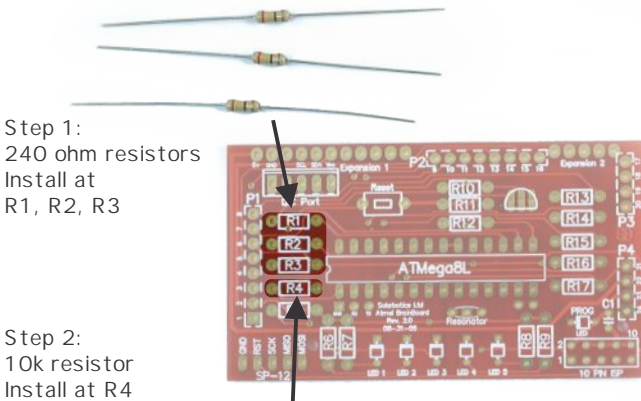

Step 1:  
240 ohm resistors  
Install at  
R1, R2, R3

Step 2:  
10k resistor  
Install at R4

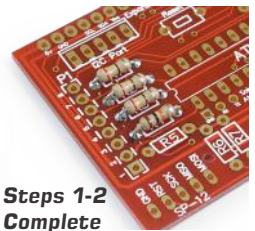

**Steps 1-2 Complete**

**Step 3 - 5 x 1k Resistors (Brown / Black / Red):** These 5 resistors are installed in positions **R5, R6, R7, R8, & R9**. These resistors limit the current going to the red tiny indicator LEDs (yet to be installed).

**Note:** If you need extra I/O for other purposes, you can re-use these ports by leaving these resistors out. Of course, then you have no blinky lights!

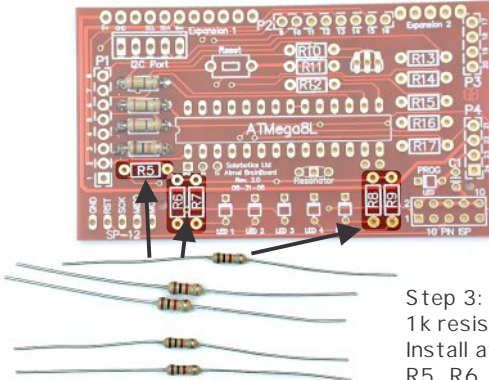

Step 3:  
1k resistors (x5)  
Install at  
R5, R6, R7, R8, R9

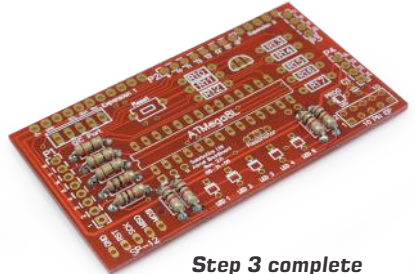

**Step 3 complete**



# The ATmega8L Brainboard



Steps 4, 5, 6

**Step 4 - 100k (Brown / Black / Yellow) Resistor:** Install the 100k resistor in position **R10**. This resistor works with the transistor to turn on the programming LED.

**Step 5 - 2 x 47k (Yellow / Violet / Orange) Resistors:** The 47k resistors are installed in positions **R11** and **R12**. These are the 'pull-down' resistors for the motor enable lines, which keeps the motors off by default.

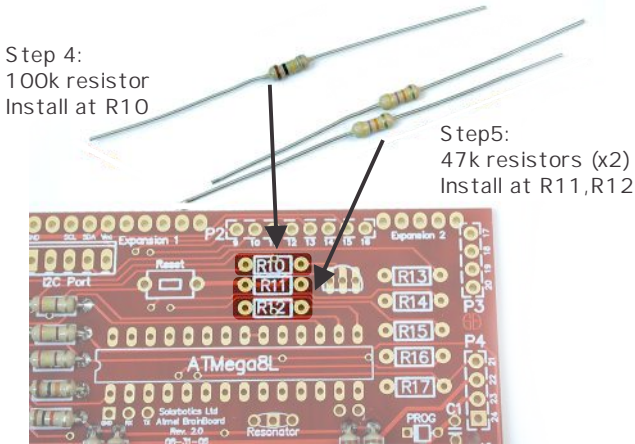

**Step 6 - 5 x 10k (Brown / Black / Orange) Resistors:** The 10k resistors are installed in positions **R13, R14, R15, R16, and R17**. These are the 'pull-up' resistors for the five edge-detection sensors.

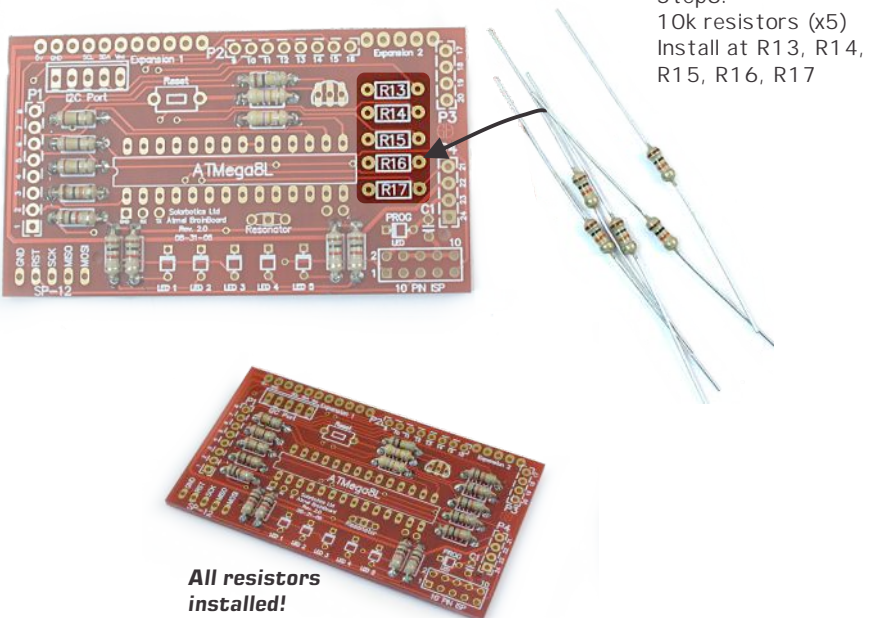



**Step 7 - Tiny Red Indicator LEDs:** You can't have a robot without blinky lights. Really. Besides, they truly are useful for figuring out what your robot is thinking at any moment.

Unlike resistors, these have to be installed the right-way-around. Look underneath the LED to see which side has the painted bar. That's the side that goes nearest to the bar symbol on the PCB.

Put the red ones in positions **LED 1** through **LED 5**.

**Step 8 - Tiny Green Programming LED:** This LED is on when connected to the programmer, and flickers during the download process. Note that you can also use this LED as an indicator via software.

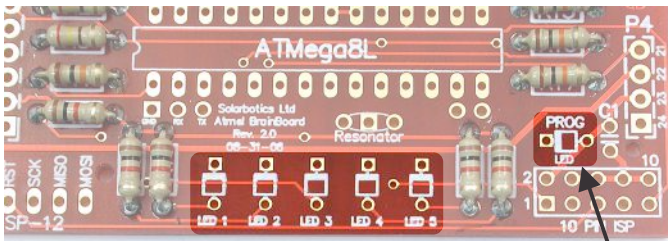
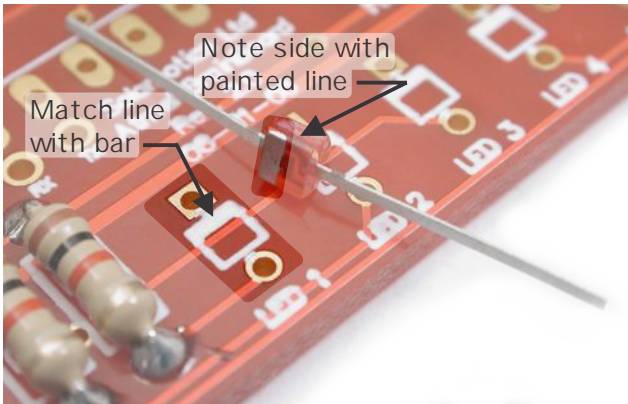

Step 7:  
Red Indicator LEDs (x5)  
Install at 'LED 1' thru  
'LED 5'



Step 8:  
Green programming LED  
Install at "PROC LED"



# The ATmega8L Brainboard



Steps 9, 10, 11, 12

**Step 9 - Reset Button:** Sometimes you have to reach out and ... make that robot behave! We do this by installing the reset pushbutton at position **Reset**. The holes may be a little snug, so if you want it to sit flat to the PCB, use some force to get it in there.

**Step 10 - 2N3904 Transistor:** Install it in the position shown, with the curve of the transistor matching the **curve** shown on the PCB.

**Step 11 - 0.1 $\mu$ F Capacitor:** This capacitor is installed at position **C1**. It doesn't matter which-way around it goes.

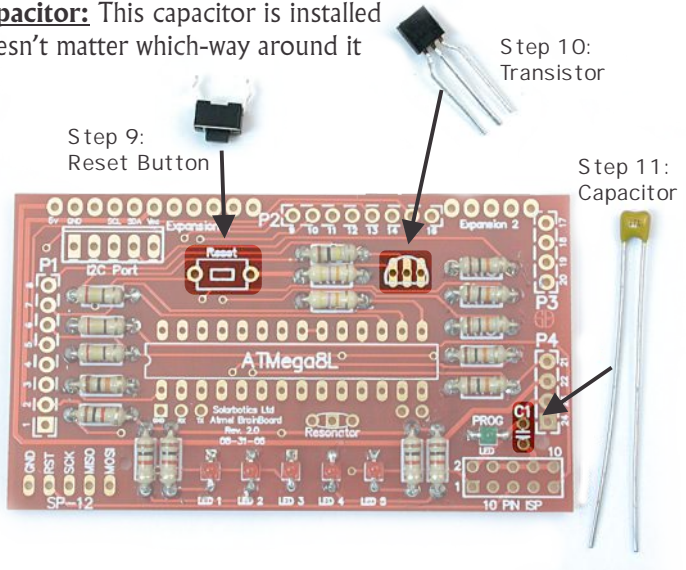

**Step 12 - Chip Carrier:** "Why not just solder the chip right in?" you may ask. Think about the trouble you'd have removing it if it failed, or was installed backwards! Try to install it with the notch matching the one on the PCB, ok?

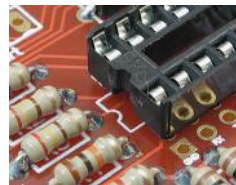
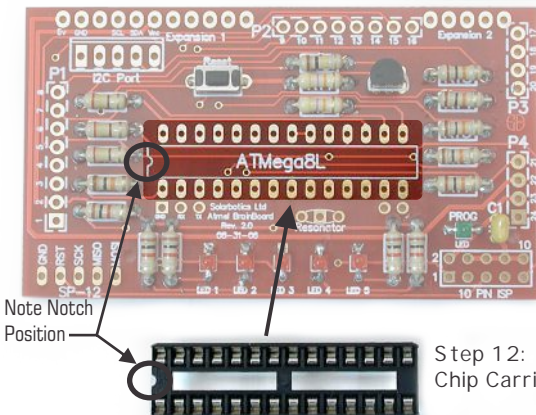

**Carrier installed.  
Note notch position!**





# The ATmega8L Brainboard



Steps 13, 14, 15

**Step 13 - I<sup>2</sup>C Header:** Going to interface to other I<sup>2</sup>C peripherals? You'll need to install this header. Make sure the big flat tab is nearest the top of the PCB, where the long line is shown on the symbol. Install it in the position marked **I<sup>2</sup>C Port**.

**Step 14 - SP-12 Header:** If you're planning on using a build-it-yourself parallel-port programmer, you'll need to install the 5-socket header at location **SP-12**.

**Step 15 - 6 Pin ISP Header:** The 6-pin ISP ("In Circuit Programming") header interfaces with most popular Atmel programming tools. Install it in position **6 Pin ISP**.



Step 13:  
I<sup>2</sup>C Port

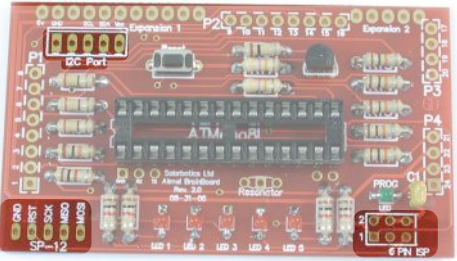

Step 14:  
SP-12

Step 15:  
6 Pin ISP  
(2 rows  
of 3 pins)



**I<sup>2</sup>C Header:**  
**Note tab position!**

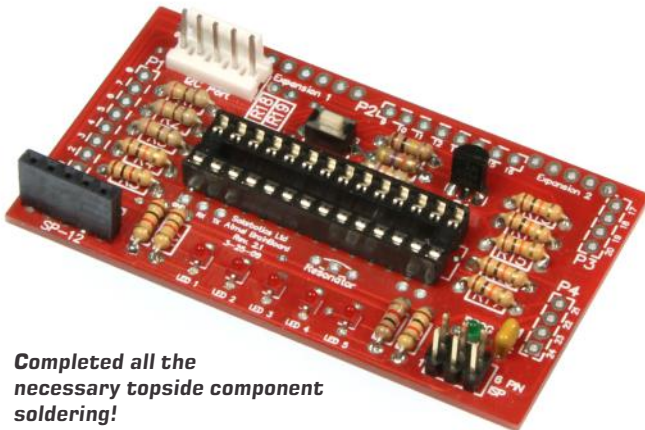
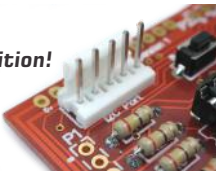

**Completed all the  
necessary topside component  
soldering!**

You're almost done. With the exception of the expansion sockets (later), you're done on the top-side. Let's flip the PCB over, and work entirely on the other side to install the mounting pins.



**Step 16 - 8 Pin Headers (x 2):** To attach your new Brainboard to the robot, you'll need to solder the two 8-pin headers in positions **P1** and **P2**, but on the underside. I don't think you heard me, so...

**NOTE / IMPORTANT / READ ME, DARN IT:** Install all these pins on the bottom of the PCB. See the dashed outline around P1, P2, P3, and P4 on the top of the PCB? That means "This is where they go, but on the bottom." There. Hope we've made that clear! (Once more: "Solder them on the bottom!")

## Step 17 - 4 Pin Headers (x 2):

Just like with the 8-pin headers, install these on the underside, in locations **P3** and **P4**.

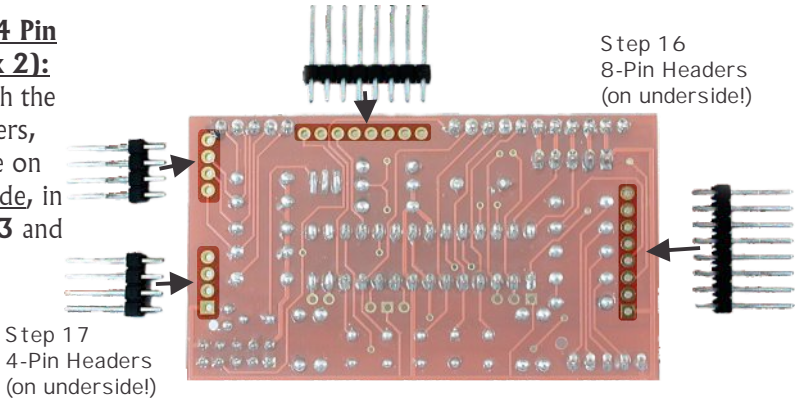

**Another Important Note! Yes, ANOTHER one!:** As these pins will mate with the sockets on the main robot body, you should try to get them installed as straight as possible. If you don't get them straight, you'll be fighting to match up all the pins to all the sockets! Here's what we suggest you do:

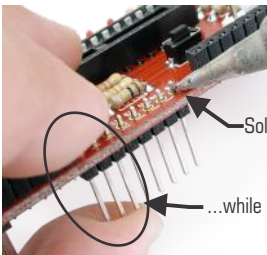

Hold in the pins with your fingers, and solder just one on the other end of the strip.

Solder here...

...while holding here!

Bend the strip until it sits perfectly upright (like shown here), then solder the rest of the pins!



**Finished Pin Installation!**

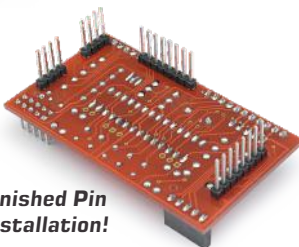



# The ATmega8L Brainboard



Step 18, 19

**Step 18 - Short Expansion Port Headers:** Although you may not use an expansion board immediately, it's best to install the headers now so they don't get lost. Install them on the **top-side** in **Expansion 1** and **Expansion 2** spots. These headers are special in that they're short, specially selected to mate with short-pins on the expansion breadboard.

*Note:  
We're working  
on the top again!*

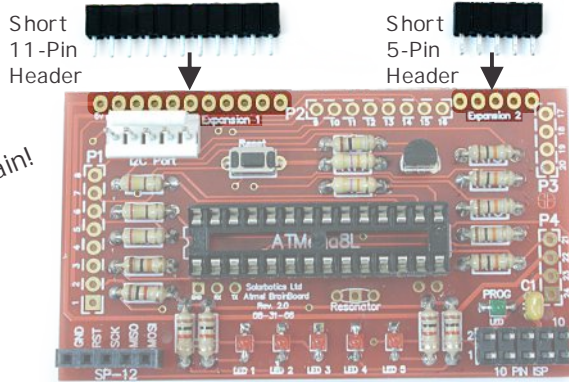

**Step 19 - Install Atmel ATmega8L** - This is a static-sensitive part, so if you frequently "zap" people, you'll have to be careful. Do this near a sink, and touch the metal faucet just before doing this, as it will remove any static charge.

Insert the Atmel microcontroller. Note that the notch on the end of the chip must match the notch on the PCB, which is on the left side.

As the chip has legs that splay out a bit, you might want to bend the legs inward so it fits into the chip carrier easier.

Gently bend all the chip pins inwards.

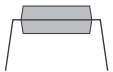

Starts like this...

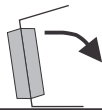

(repeat for each side)

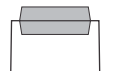

...ends like this!

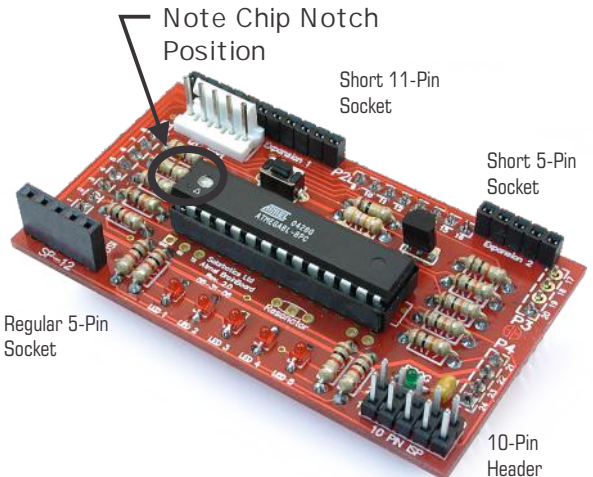



# The ATmega8L Brainboard



## Step 20

On the Sumovore, you have to add the center edge-sensor to make full use of the Atmel Brainboard:

**Step 18 - Installing the 5th line sensor:** Yank the edge-sensor board out of your Sumovore, and install the included line sensor in position 'Edge3', just like you did when you originally built your Sumovore.



Step 18: Add the 5th line sensor

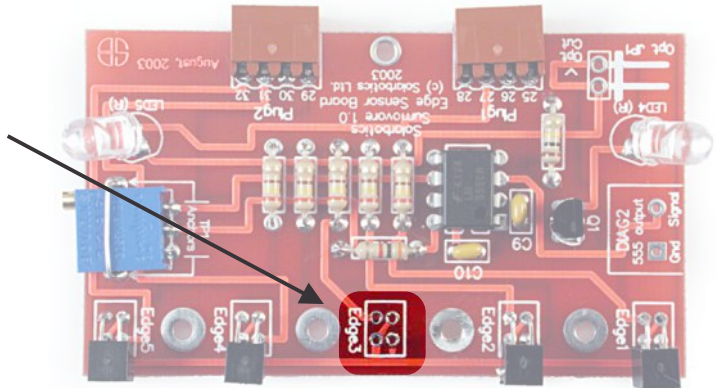

The Brainboard has some pretty cool additional features which you may never need to use, but they're here if needed:

- Unregulated 6V power from the main 4-cell battery pack
- Microcontroller TTL serial port access (needs external RS232 level shifting)
- Location for installing external resonator (used for precision timing), which also can be used as additional I/O (PB6 / PB7)
- Tap points for utilizing unused PD7 & PBO pins

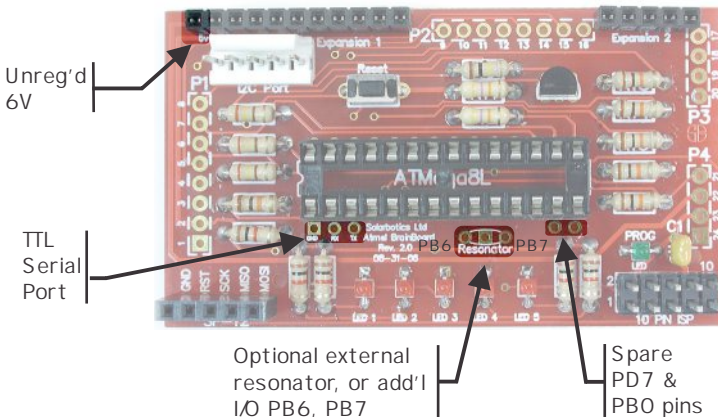



# The ATmega8L Brainboard



## The SP-12 Programming Cable & Programming Introduction

**SP-12 Programming Interface:** If you're doing this on-the-cheap, you'll most likely program the Brainboard via your computer's parallel port (most often connected to a printer cable). The SP-12 serial programmer is released under the GNU license by Ken Huntington, Kevin Towers, and Pitronics (learn more at [http://www.xs4all.nl/~sbolt/e-spider\\_prog.html](http://www.xs4all.nl/~sbolt/e-spider_prog.html)). We've combined some of the parts (the resistors, transistor, LED) into the brainboard to make building the cable a simple project. Find a discarded printer cable, and get hacking!

### SP-12 Physical Wiring Diagram

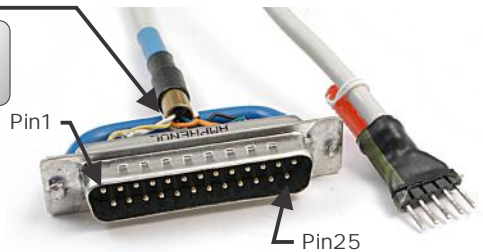
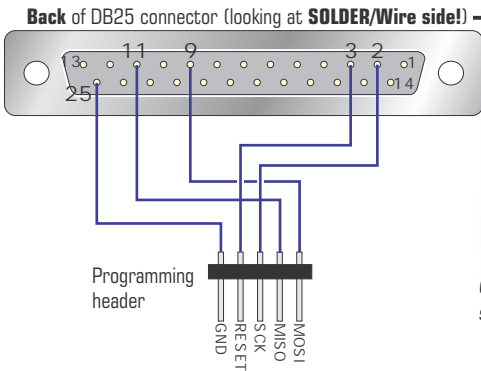

**Completed cable, with heatshrink sleeve and scrap plastic 5-pin header support**

**Your ATmega8L comes pre-programmed, ready to go**, but if you want to make changes, you'll need a "development suite" to help you program, compile and download to your robot. Most people start by using "C", so we suggest using the "GNU C Compiler" (aka: "GCC") with "WinAVR" from <http://winavr.sourceforge.net/> (on the Windows XP™ platform). Install the package, and make sure you run the "giveio.bat" program, which enables direct port access. Full installation notes are available with the download, or from the "resources" section for the Brainboard at <http://www.solarbotics.com>.

Connect the cable the robot and the PC. **Disable the motors** on your robot before powering the robot on (use the robot's motor enable switch). A good connection makes the green programming LED glow. No light = no connection, so make sure the cable is connected the right-way around to the robot.

Grab the latest code from our website, and open the "Sumovore\_2.proj" project file with WinAVR, which will automatically load up all the support files. "Click on "Tools", then "[WinAVR] Program". This creates the machine code, and downloads it to the robot!

There are three sections to the code, startup, Sumo, and the Line-follower. If you start your Sumovore on a black sumo-ring surface, the low signal from the edge sensors kick into sumo mode. White surface reflection (white table with black electrical tape line) kicks the Sumovore into running the line-follower routine.



# The ATmega8L Brainboard

## Programming the BrainBoard



### Atmel STK-500 Programming Interface:

The STK-500 is a handy, inexpensive interface board from Atmel that lets you program practically all Atmel microcontrollers. This brainboard interfaces with it via the “ISP6PIN” header. Match up the “Pin1” lines with the red stripe on the cable, and **make sure** the motor enable switch is off. If you don't, the STK-500 will try to power up the motors.

Using “GCC” sourcefiles from Solarbotics.com, open “Sumovore\_2.aps” into the AVRStudio programming suite. “Sumovore\_2.c” and “Sumovore\_2.hex” will automatically open.

Turn on the STK-500, and click the “CON” (connect) button, which looks like a small IC chip. In the pop-up window, you'll want to make sure the following settings are in place:



Under the Program tab:

Device = ATmega8

Programming Mode = ISP w/checks in both boxes to the right

Flash = (click the “...” button and load the Sumovore\_2.hex file)

EEPROM = (not being used at this time)

Under the Fuses tab:

Checks should be in the following boxes:

Serial programming enable will be grayed out with a ? in the box.

Boot Flash size = 1024

Brown out detection = 2.7v

Int. RC Osc. 8Mhz 6CK + 64ms

To program the Brainboard, click on the “Program” tab. The “Flash” section has a “Program” button - click it, and watch the green LED on the brainboard flicker as the code loads into the microcontroller. Shut off the STK500, remove the cable, re-enable the motors, and power up the robot!

If the robot is activated on a black surface, it will chase a huge Japanese guy around the ring\*, if it's on a white surface when powered up it follows a black line.

\*Huge Japanese Guy not included with kit. They cost too much to ship.



# The ATmega8L Brainboard

## Brainboard Schematics



### ATmega8L Microcontroller

#### Pin Usage

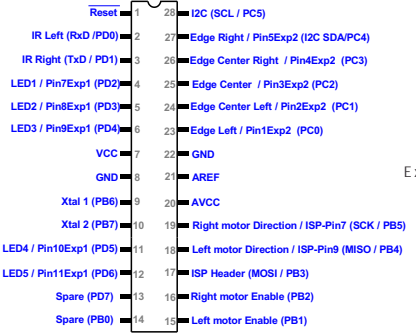

### Brainboard I/O

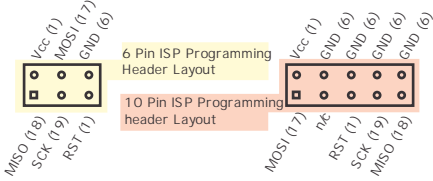
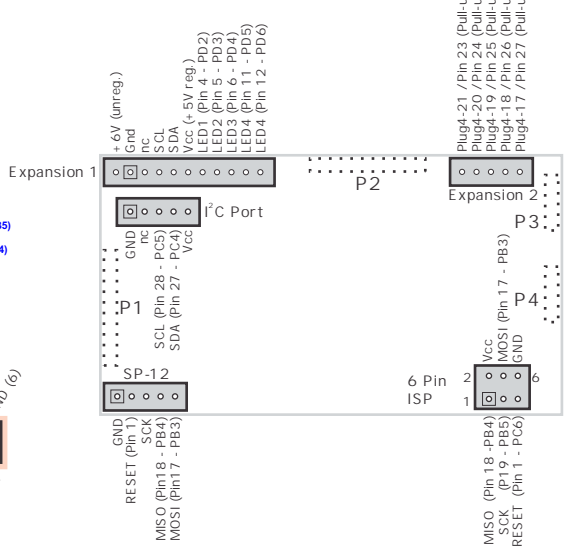

### Brainboard Schematic

(drawn with approximate component placement)

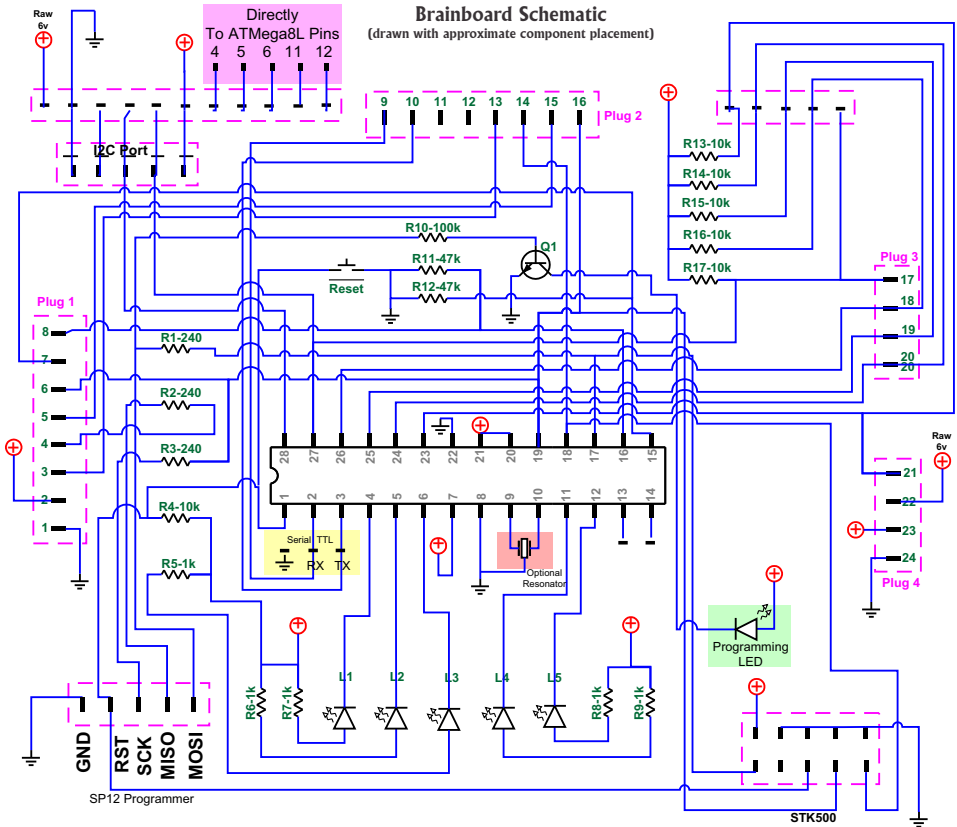

Visit us online for more info and cool stuff:

[www.solarbotics.com](http://www.solarbotics.com)

**Solarbotics Ltd.**

3740D - 11A Street NE, Suite 101  
Calgary, Alberta T2E 6M6  
Canada



**Toll Free:** 1-866-276-2687

**International:** +1 (403) 232-6268



**Fax:** +1 (403) 226-3741



Made in Canada