



## MsMot Mini-shield for two 3 - 5V motors

The minishield is connected only to the pins it uses. Use it with your proto shield and you control 2 motors in addition to the sensors being tested. As most motor shields, pins 4,5,6,7 control the motor, with PWM on pin 5 and 6. The drivers are the Si9986, 3 to 6V, 1A max, 300 mA with only 0.2V loss (compare with the L293).

The great thing about this small module is that bicolor Leds are provided to show the motor control signals, and a switch disable the power on the motors when they have no reason to spin during software development. Bicolor leds feedback provide direction and approximate speed. Let's develop with leds and not noisy motors !

MsMot is not suited for cheap toy motors, but nice 10 to 30 Ohm motors are easy to find, and less noisy. When batteries are required, e.g. for a mobile robot, a connector is provided and will also power the Arduino board.

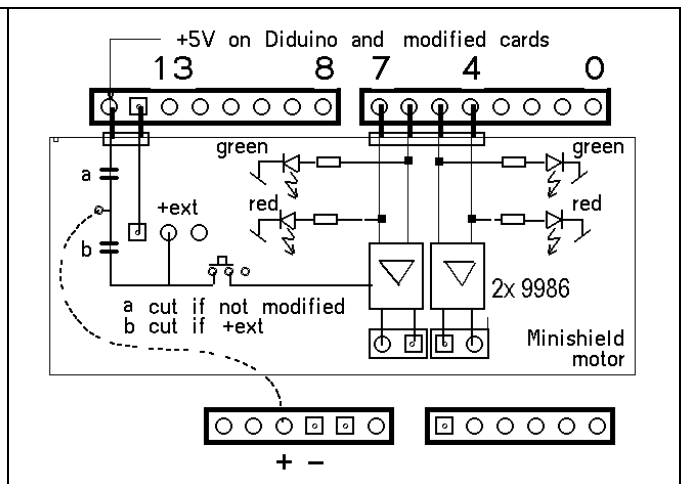
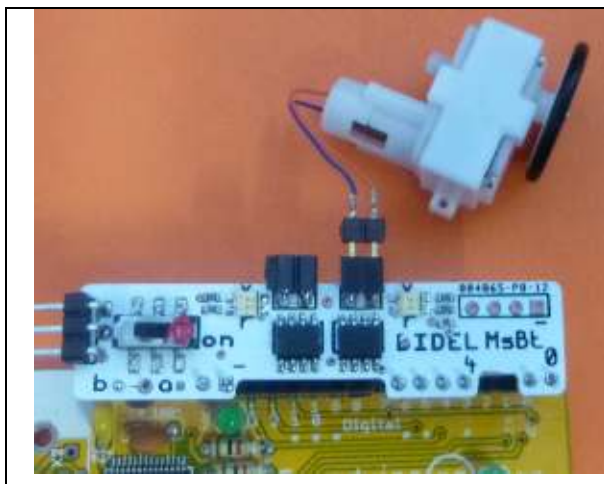
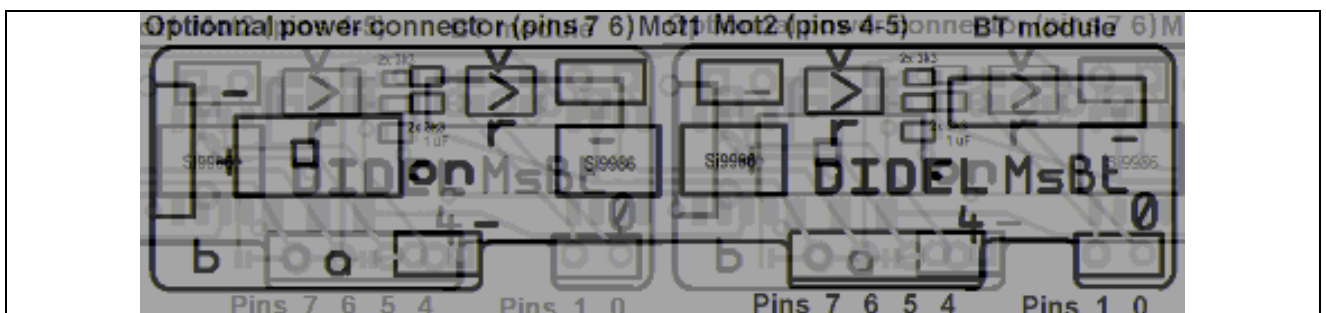

### Power source

By default, +5V is taken from upper left pin of the Diduino board. This pin is the +ref pin of Arduino and several boards supply a limited amount of power on that pin. The Diduino board is not compatible for that pin: A + 5V is really convenient at that place.

If you need to power from the usual +pin, a 50mm wire with a 0.7mm pin at the end must be added and bridge "a" must be open. If the power cannot be taken from USB, bridge "b" must be open, and power is coming from the "ext" pin on the "Gabriel" 3-pin connector. Voltage can be lower than the 5V or 3.3V of the card, but it must not exceed it.

