

# Secret L293D Motor Driver

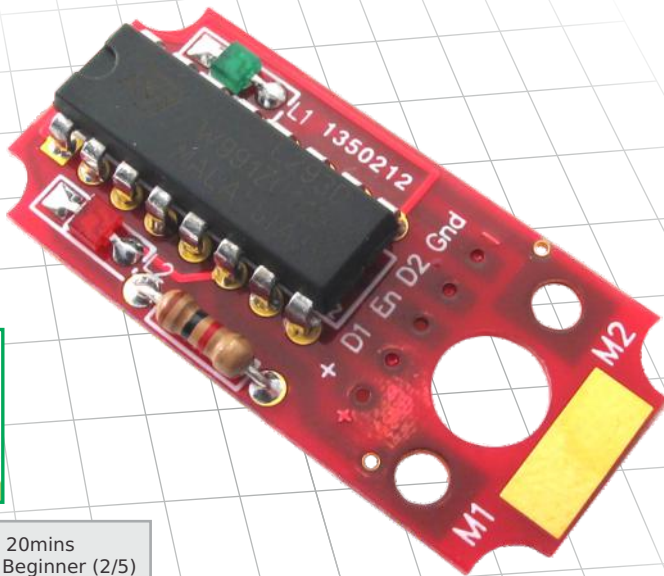

**Build Time:** 20mins  
**Skill Level:** Beginner (2/5)

For robots that need to be lean, mean, and effective, the Solarbotics 'Secret' L293D motor driver replaces the guts of standard servos with the power of the robot-friendly L293D motor driver chip.

It fits right inside most standard servo bodies, to give your robot more power from a tighter space!

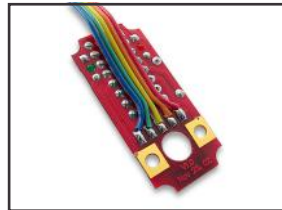
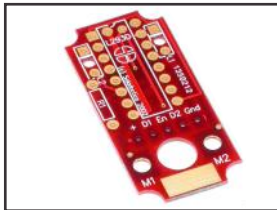
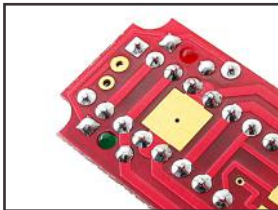

This page left intentionally blank (we think...)

---

# TABLE OF CONTENTS

Table of Contents. . . . . (i)

Parts List . . . . . (ii)

Introduction. . . . . 1

Construction

    Steps 1 - 2 (IC, 1k resistor) . . . . . 2

    Step 3 (LED Installation). . . . . 3

    Step 4 (Wiring) . . . . . 4

    Steps 5 (Closing it up) . . . . . 5

Usage . . . . . 5

Option 1 - 5V IC Logic. . . . . 6

Option 2 - Servo Rotation Fix . . . . . 7

Option 3 - Breadboard Use . . . . . 8

Performance Characteristics. . . . . 9

Schematics . . . . . 10

Other Motor Usage . . . . . 11

Contact Information . . . . . 11

## PARTS LIST

- 1 - Suspiciously small red printed circuit board (PCB).
- 1 - L293D motor driver chip (the star of our show!).
- 2 - LEDs. Light-emitting diodes. Cool, small ones.
- 1 - 1k current - limiting resistor. (Brown /Black /Red / Gold).
- 1 - Length of 5 conductor ribbon cable



We strongly suggest you inventory the parts in your kit to make sure you have all the parts listed (c'mon - there's barely a handful of parts, so count them!). If anything is missing, contact Solarbotics Ltd. for replacement parts information.

### Disclaimer of Liability

Solarbotics Ltd. is not responsible for any special, incidental, or consequential damages resulting from any breach of warranty, or under any legal theory, including lost profits, downtime, good-will, damage to or replacement of equipment or property, and any costs or recovering of any material or goods associated with the assembly or use of this product. Solarbotics Ltd. reserves the right to make substitutions and changes to this product without prior notice.

## INTRODUCTION

One of the first realizations in robotics is that making something move isn't an easy task. You simply can't take a "brain" circuit and connect it to a motor and expect anything to happen. The motor will simply say "HAH!" at the puny output signal from the brains, and stay still. What the brain needs is an enforcer. Muscle. Something to convince the motor to do things the way the brains want it to be done.

There are many ways to strengthen ("buffer") a signal so it's strong enough to drive a large load like a motor. Transistor H-bridge circuits, buffer chips, and dedicated motor driving chips are all suitable candidates, with their own benefits and limitations.

For our 'Secret' motor driver, we wanted something that would take standard TTL (well, CMOS too) inputs and make a standard servo our slave. You see, standard servos use a "Pulse Width Modulated" ("PWM") signal to tell a servo where to rotate to. PWM works by sending a rapid train of high/low signals to the servo's regular driver brains, and depending on how different the high signal is from the low signal, the servo moves to the according position. PWM is great if you don't want to rotate much more than 180°, which is fine for actuators, but not for driving wheels.

With our 'Secret' motor driver and a bit of servo hacking, we're going to lobotimize and turn a standard servo into something more useful - a small, compact, powerful gear motor! It'll be something you can use very simple input signals to control it's rotation. We'll even throw in a 5V regulator hack if you want to clamp the voltage right at the servo. Or, modify it for use on a breadboard, which will make good use of the driver's indicator LEDs to show direction of rotation.

Ohhh, it's time to get to work! (This'll be great...)

# CONSTRUCTION

Note notch position

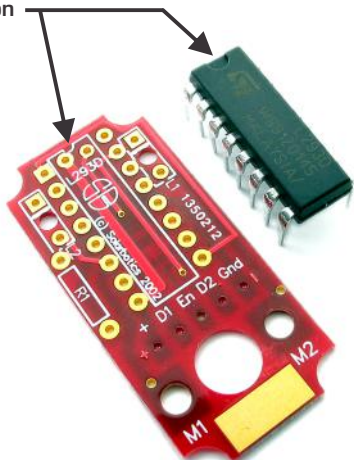

## Step 1: Installing the IC

The L293D is a 16-pin chip with a little notch cut out of the front of it (that last bit is for you non-experts). Orient the chip so the notch matches the notch in the chip outline on the PCB. Carefully drop the chip into the gold-plated (pretty uptown, eh?) pads, and solder it into place from the other side.

To avoid any nasty punctures, clip off any excess pins that poke through the pads on the solder side.

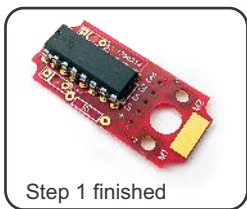

Step 1 finished

You might find it useful to bend over a pair of corner pins to hold the chip in place when you flip the PCB over.

## Step 2: The 1k Resistor

The 1k resistor (brown /black / red / gold) is inserted in about the only position it can fit into - position 'R1'. Snug it up close to the circuit board, bend the leads over, and solder it into place from the other side.

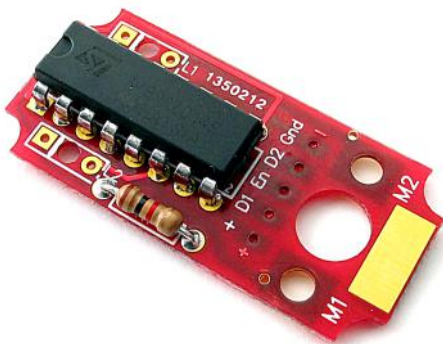

When done, clip off the excess leads.

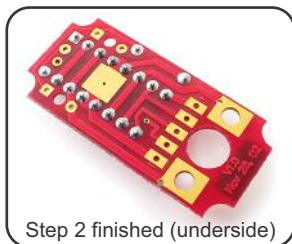

Step 2 finished (underside)

# CONSTRUCTION

## Step 3: LED Installation

This is one of the really cool things about the 'secret' driver board - the LED indicators. You have the option to mount them upside-UP or upside-DOWN. We recommend upside-DOWN, so you can easily see them from either side. Of course, none of this is necessary if your servo case isn't transparent.

The tiny LEDs in your kit have a lense that can be poked into the hole of the PCB which can easily been seen if you use the driver board on a breadboard, or in a transparent servo case (like the Solarbotics GM4 motor). Don't worry - you'll still see the LED light up from the other side too!

NOTE: Upside-down or upside-up, just as long as the lead near the painted bar on the LED (the cathode) goes into the square pad hole, and matches the bar printed on the PCB! If they aren't installed properly, they aren't going to light up!

Tiny LEDs mounted upside-down with lense in hole

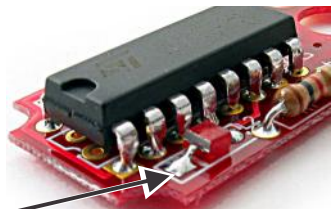
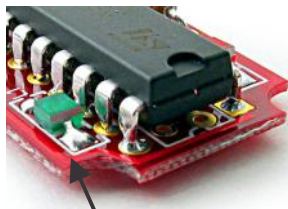
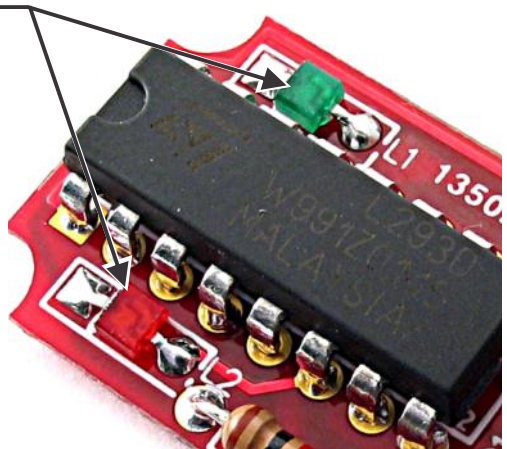

LED "cathode" mark nearest square pad

## CONSTRUCTION

### Step 4: Wiring & Installation

Your kit comes with a set of five (5, for those who can't read "five") conductor ribbon cable. You'll have to split the ends apart, and strip off about 1.5mm (1/16") from each end. Try to arrange your ribbon cable like the one below, as splaying them apart will make it easier to solder each end to the driver board. For easier soldering, pre-tin the ends of each wire.

Starting with the red wire on the side nearest the pad marked '+', start soldering them into place, one per pad. We'll be using the wire colours for different functions.

**IMPORTANT:** If possible, solder the wires down on top of the pad - not through. The metal motor case underneath can (and will!) short out leads that poke through the PCB. If you have to use the holes, trim the excess lead off flush with the bottom of the PCB.

If you want to use your motor driver on a breadboard, skip ahead to "Option 3".

When done, drop the wired PCB into the servo, on top of the motor tabs. Solder the motor tabs to the PCB, and you're ready to close it up!

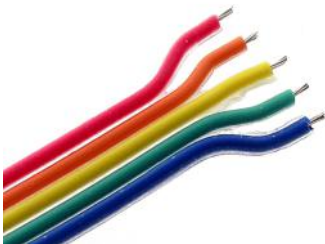

Stripped and splayed...

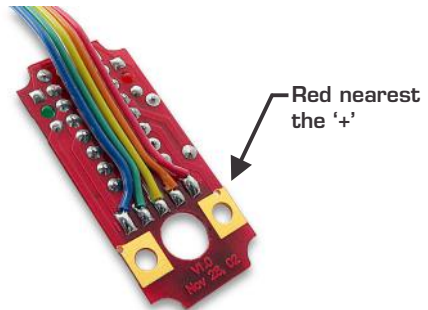

...and soldered on TOP of the pads...

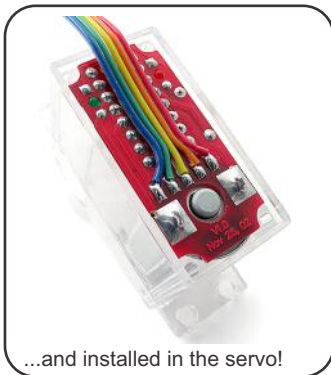

...and installed in the servo!



See? It fits in other "standard" servos too.



## CONSTRUCTION

### Step 5: Closing it up

No rocket science here - simply put the servo bottom plate back in place, insert the corner screws, and tighten them down.

Be careful to fold over a few of the edge ribbon wires, as it'll be too wide to fit the slot that originally fit only three wires. Or hey - be a rebel and use a knife (or other favourite tool of destruction) and widen the slot so all five wires lay flat.

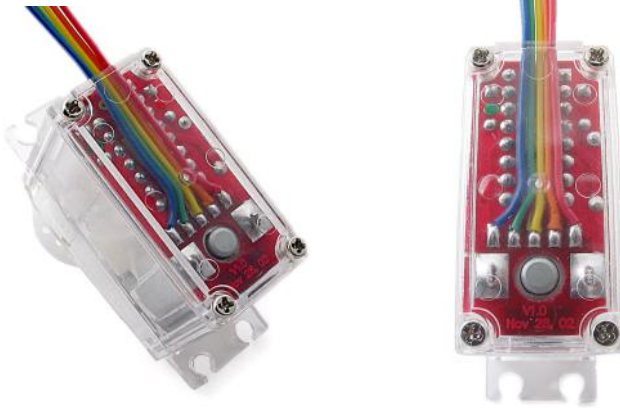

## USAGE

So you want to know how to use it? It ain't too difficult. Here's the long and short of it:

- Red - Vcc ('+')
- Blue - Gnd ('-') (on the opposite side of the cable)
- Orange & Green - D1 & D2 (direction power flow of motor outputs)
- Yellow - Enable (turns the chip off - connect to gnd to turn it off).

Connect the red ('+') and blue ('-') to power. Leave the yellow line alone, unless if you want to turn the chip off, or pulse it to slow the motor down (a technique called "Pulse Width Modulation). Connect D1 to 5V, D2 to gnd, and the motor will turn one way. Connect D1 to gnd, and D2 to 5V, and the motor turns the other way. Connect D1 and D2 to either 5V or gnd, and the motor is in "brake" mode (try turning it - hard to do, eh?).

Connect the yellow line to gnd, and it doesn't matter what D1 and D2 are connected to, as the motor is in "coast" mode, as if it weren't connected to the motor driver board at all!

## OPTION 1 - 5V IC LOGIC

Although the SGS Thompson L293D can take logic and motor voltage of up to 36 volts, we don't recommend running both beyond 12 volts. The VccL line really only needs 5 volts to run the "brains" of the chip. Beyond that, you start consuming the valuable power-handling ability of the chip for just powering the IC's brains. Not good. By clamping it down to 5 volts, you're leaving more wattage capability for actually driving motors.

Fortunately, we've designed the 'secret' motor driver to utilize a very inexpensive, standard TO92 package-style (transistor-looking) 78L05 5 volt regulator (not included in the kit - this is optional, remember?).

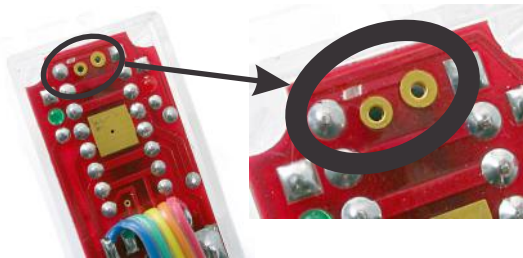

Step 1: Cut the trace. You have to isolate this pad by using a knife or other sharp instrument to cut a groove through the trace.

Step 2: Clip the 78L05 legs to about 1/3 the full length, and insert them into the two open pads. The last leg will have to be soldered to the top of the existing pad.

NOTE: Make sure the 78L05 is installed face up!

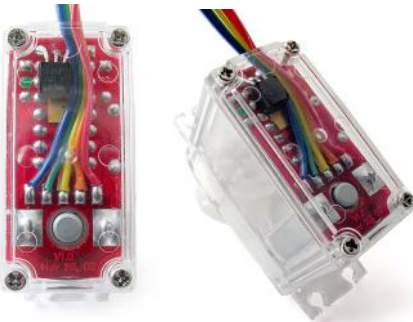

Step 3: Thread the ribbon cable around the 78L05 and out the motor case. Slap the cover on, tighten the screws, and you're running on 5V regulated! NOW feel free to crank up the voltage...

## OPTION 2 - SERVO ROTATION FIX

If you're planning to use the 'secret' motor driver in a standard servo, you will most likely have to perform a servo continuous-rotation hack. Here, we're modifying the very common Futaba S 3003 /Tower Hobbies TS-53. Most servos can be similarly modified, but there are a few that really aren't well suited to this modification. Search the Internet for "servo rotation hack" (or similar) for which work best.



Step 1: After removing the screws from the bottom of the servo, pop the top 1/3 of the servo case apart. Don't worry if a gear or two comes out, as long as you have them all for re-assembly.

Step 2: We're after the big black output gear. See how there's a tab on the side? We need to cut it off so that it can spin all the way around.



Step 3: Use a razor, thin saw, or carving tool to remove the tab. We don't recommend cutters or snips, as we've cracked the whole gear when snipping the tab off!



Test your trim job by putting the gear by itself back into the top servo housing, and spin it around to make sure it isn't rubbing. Some servos need the potentiometer removed, as they have stops built into them too.

Step 4: Reassemble the servo gear train, put the top housing back in place, and finish installing the motor driver.

There! Go forth and terrorize the world with mutant modified servos!

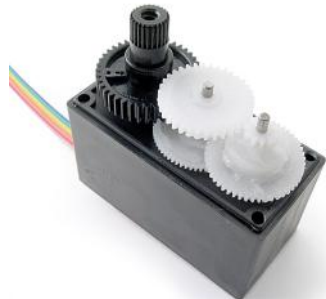

# OPTION 3 - BREADBOARD USE

So you don't want to build a robot yet - what are ya gonna do? Build the 'secret' motor driver anyways, and use it on the breadboard! You're going to need seven (7) pins to complete this option.

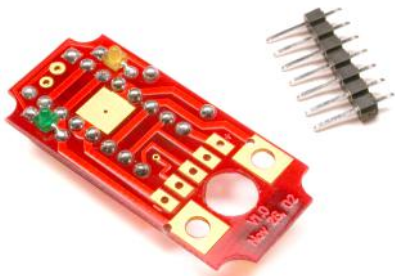

Step 1: Build the motor driver as per usual, and gather your pins.



Step 2: If you have to, snap off two singles from the pin set.



Step 3: Solder the pins into the holes on the bottom of the PCB near the pin function labels. You may need to open up the holes a bit to make them fit.

Step 4: Insert the driver board into your favourite breadboard! We found having small jumpers to the other side of the breadboard makes configuring connections easy.

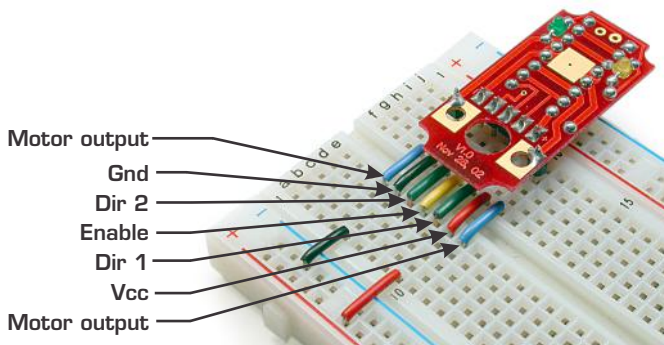

# PERFORMANCE CHARACTERISTICS

Here's the nitty gritty on the SGS Thompson L293D chip as we tested it. You can find full manufacturer's datasheets online at "<http://downloads.solarbotics.com/pdf/l293d.pdf>".

## SOLARBOTICS MEASURED CHARACTERISTICS

Test	IC Voltage		
	5V	9V	12V
Quiescent current draw, IC enabled (mA)	51.4	53.5	54.1
Quiescent current draw, IC disabled (mA)	16.4	16.6	16.6
IC input impedance (ohms)	65.3k	82.5k	140k
Output peak current (A) 0 Ohm Load	2.27	3.38	Near-instant thermal shutdown
Voltage drop across 8 ohm load (V)	3.98	7.43	9.88
Current delivered to 8 ohm load (mA)	498	929	1240
Equivalent internal resistance (ohms)	2.05	1.69	1.71

Note: The above table is correct only if your input voltages (D1 & D2) are below 12.08V. If either input exceeds 12.08 volts, both inputs automatically go logic HIGH, which brakes the motor. For best error-free performance, keep your logic levels at 0 (LOW) to 5V (HIGH).

## SGS THOMPSON DATASHEET CHARACTERISTICS

- Logic /Motor supply maximum voltage . . . . . 4.5V to 36V
- Input & enable line voltage range . . . . . 7V
- Peak output current (nonrepetitive),  $t \leq 100\mu\text{s}$  (per 2 channels) . . . . .  $\pm 2.4\text{A}$
- Continuous output current (per 2 channels) . . . . . 1.2A
- Total continuous heat dissipation . . . . . 4W
- Maximum switching frequency (ie: PWM applications). . . . . 5kHz

## LOGIC TABLE

Inputs			M1, M2 Output
Enable	D1	D2	
H	H	H	Both outputs HIGH (motor brake)
H	L	L	Both outputs LOW (motor brake)
H	H	L	Current flow from M1 to M2 (rotates dir 1)
H	L	H	Current flow from M2 to M1 (rotates dir 2)
L	X	X	High impedance (motor coasts)

- X = Doesn't matter
- H = Logic High
- L = Logic Low

# SCHEMATICS

## STANDARD 'SECRET' MOTOR DRIVER SCHEMATIC

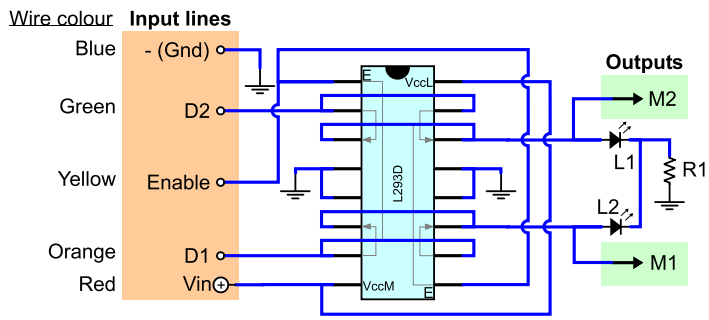

## 5V REGULATED LOGIC

### 'SECRET' MOTOR DRIVER SCHEMATIC

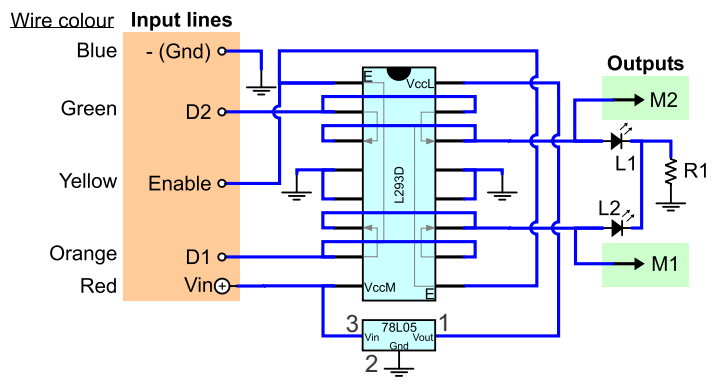

## APPLICATION - SINGLE SIGNAL LINE MOTOR DIRECTION CONTROL

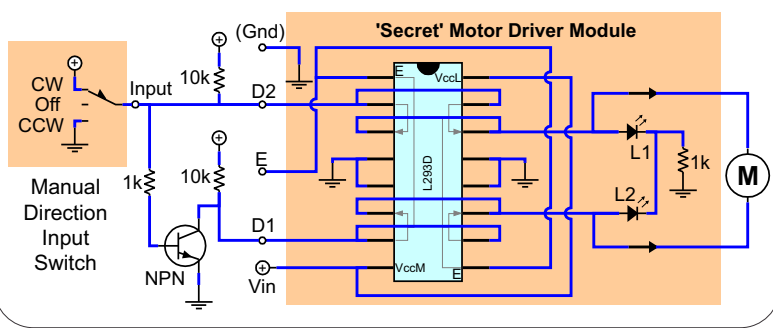

Here's a simple 1-wire control interface. Connect the input to Vcc for rotation 1 way, Gnd for rotation the other way, and nothing at all (high impedance) for " Brake".

## OTHER MOTOR USAGE

The 'secret' motor driver also fits well on the outside of the Solarbotics GM2 and GM3 gearmotor.

Run the ribbon cable the other way off the driver PCB through the motor hole (for stress relief), and glue the top of the L293D IC to the gear motor case. Use short lengths of wire to connect the output pads of the motor driver to the motor contacts, and you're in business!

In the case of the dog-leg inline GM2 motor, you might want to trim off one of the motor retainer clamps so you have a convenient flat mounting location.

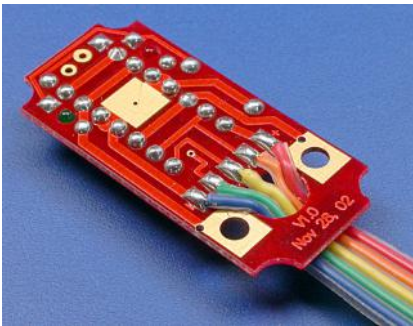

Run the wires through the hole

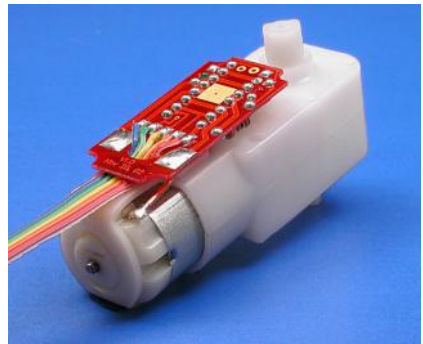

The GM3 installation



The GM2 installation - note the clipped motor retainer under the PCB

For kits, parts and technical support, contact us at:  
Solarbotics Ltd.  
201 - 35th Avenue NE, Calgary, Alberta, Canada T2E 2K5  
Ph: (403) 232-6268 Toll-Free: 1-866-276-2687  
Fax: (403) 226-3741  
info@solarbotics.com / www.solarbotics.com

# Psst! Hey buddy....

- ▶ Building a Mini-Sumo Robot?
- ▶ Want to run more voltage through your servo?
- ▶ Need more power?

I've got a secret for you:

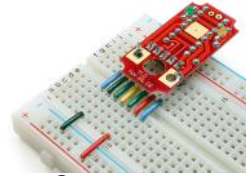

The Solarbotics 'Secret' L293D motor driver - for applications where space is tight, and power needs are great! Sneak this module inside a servo for more power and flexibility for your robot designs.

It's Powerful: Configured with LED direction indicators, able to deliver 1.2A of current (2.4A surge) and 36 volts supply power, this module has more than enough ability to turn your 'hobby' servo or gear motor into a real workhorse!

It's Breadboard Friendly: And if a stealthy install doesn't interest you, add seven pins to the option pads, and you have a power driver module you can use on a breadboard.

The 'Secret' L293D motor driver is a perfect match for the Solarbotics GM4 gear motor. With the transparent motor case, you can monitor the driver's indicator LEDs!



Visit us online for more info and cool stuff:

[www.solarbotics.com](http://www.solarbotics.com)

**Solarbotics Ltd.**  
3740D - 11A Street NE, Suite 101  
Calgary, Alberta T2E 6M6  
Canada



**Toll Free:** 1-866-276-2687  
**International:** +1 (403) 232-6268



**Fax:** +1 (403) 226-3741



Made in Canada