

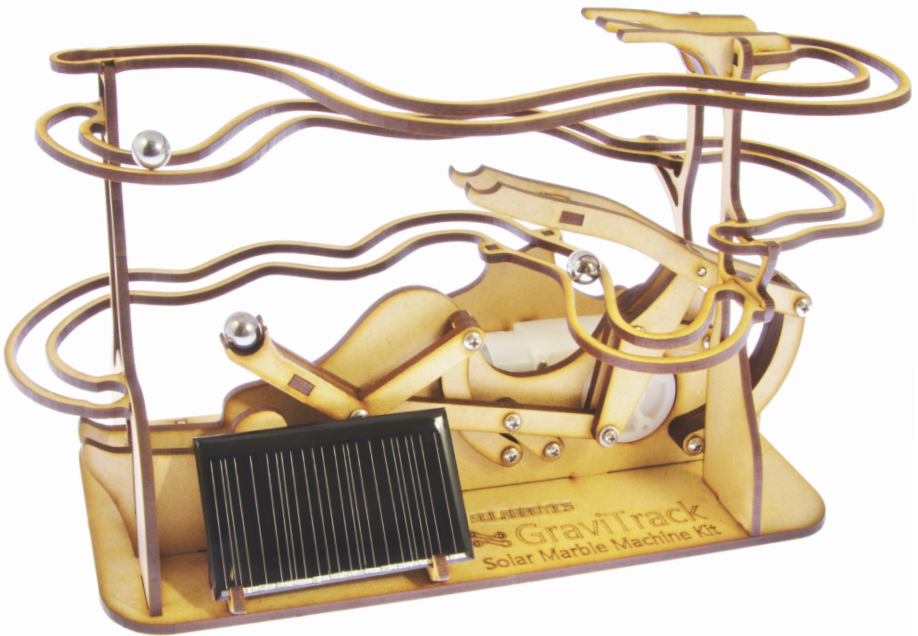

GraviTrack Solar Marble Machine Kit

Use solar power to drive the mechanism in this elegant, two-handed marble machine.



Intermediate skill level - ages 12+



No batteries included (or needed - it's solar powered!)



Basic soldering tools required
(soldering required)



3 hours build time



www.solarbotics.com

1-866-276-2687

solarbotics.com/products/60415/
Document revision: October 6 2017

PARTS LIST

Set of laser-cut wooden parts

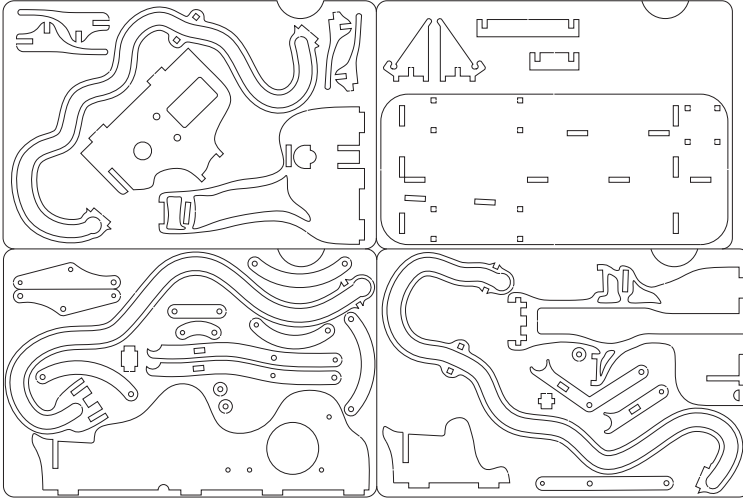

GM3 Motor

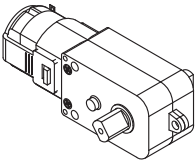

1 x GMW
Motor mount



4700 F
Capacitor



PN222A
transistor



1381 or
MCP112
trigger



0.47µF
capacitor



Diode



4 x 0.375"
steel marbles

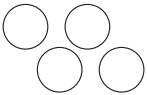

1 x #2
washer



Double-sided
sticky tape



SolarEngine
circuit board

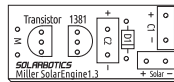

37x66mm solar cell

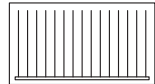

*parts to scale

3 x 1/4"
4-40 screw



2 x 1/2" #4
TF screw



1 x 1/2"
4-40 screw



2 x 5/8"
4-40 screw

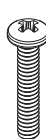

3 x 3/8"
4-40 screw



1 x 1/2"
#2 TF screw



TOOLS REQUIRED

- Soldering equipment (soldering iron, solder)
- Philips screwdriver
- Wire cutters
- White glue
- File/exacto knife

ASSEMBLY STEPS

The SolarEngine is a clever circuit that allows solar energy to be harvested and used even in low light levels. We're building and testing this part of the project first. There is soldering required, so if you are new to the process, review the "how-to" link below.

 The introduction to soldering video: slrbtcs.co/solderVid2

Step 1. SolarEngine Circuitry

1.1

Find the transistor(g), trigger MCP112 (h) - also looks like a transistor), small 0.47 μ F capacitor (j) and diode (l) and clip the paper off the end of the leads.

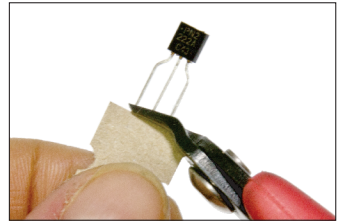

1.2

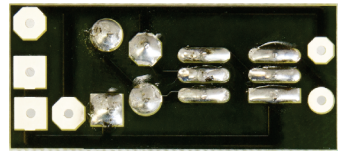
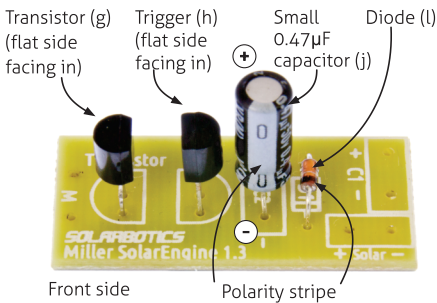

Install these parts to the SolarEngine circuit board (m) as shown, nice and tight to the circuit board. Bend the leads on the other side, so the parts stay in place while you solder - no need to hold them and potentially burn your fingers.

Make sure to match the orientation markers & stripes - these components do not work backwards.

1.3

Prepare the large 4700 μ F capacitor (e) by gripping it with the stripe facing you. Bend the leads 90° over to the left:

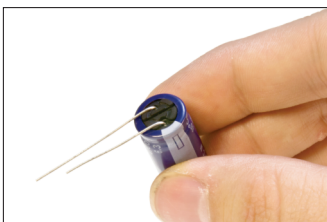

Install it to the SolarEngine as shown. When finished, clip any leads sticking through the bottom of the circuit board so the bottom is nice and neat.

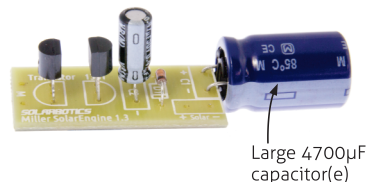

ASSEMBLY STEPS

1.4

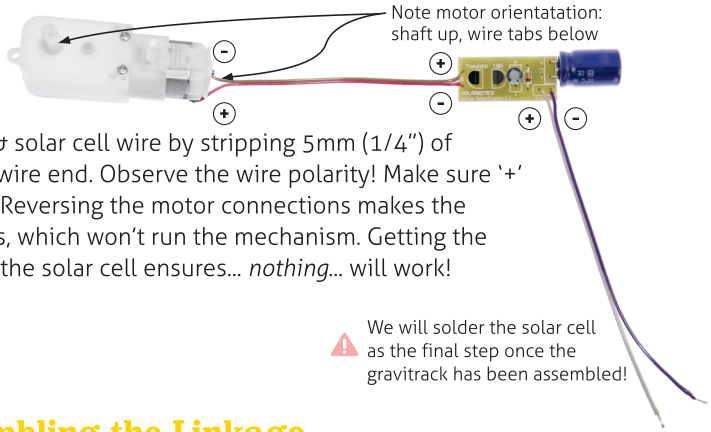

Prepare the motor & solar cell wire by stripping 5mm (1/4") of insulation off each wire end. Observe the wire polarity! Make sure '+' goes to '+', '-' to '-'. Reversing the motor connections makes the motor go backwards, which won't run the mechanism. Getting the wires backwards to the solar cell ensures... *nothing*... will work!

⚠ We will solder the solar cell as the final step once the gravitrack has been assembled!

Step 2. Assembling the Linkage

All the laser cut parts are labeled and marked per panel. It's now the simple process of find, prepare, and assemble!

2.1

Panel 3 has your linkage base (A). Locate the small curve (B), small arm (C), and 3 x large curves (D). Use the screwdriver to remove any sticking cutouts.

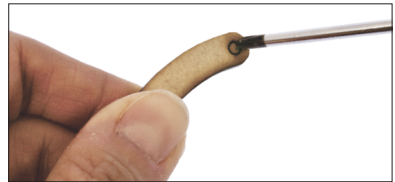

2.2

Assemble the pieces to the linkage base as shown. Make sure the larger of the two holes of the small arm (C) is used to attach it to the base (2x 1/4" screw, 1x 1/2" screw).

⚠ Tighten the screws so the pieces can move without friction but stay flat against linkage base. So make them tight but not too tight so they can't move smoothly.

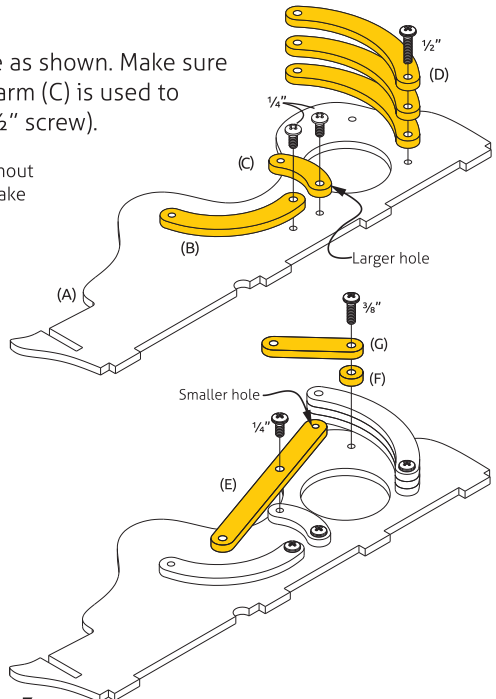

2.3

Assemble spacer #1 (F), and medium arm (G) and from Panel 3, and the large arm (E) from Panel 2. Remove any cutouts and attach to the linkage base as shown (1x 1/4" screw, 1x 3/8" screw).

ASSEMBLY STEPS

2.4

From panel 3, get Triangle #1 (H) and Triangle #2 (I), and attach to the linkage base as shown. Install Triangle #1 (H) on the bottom (1x 3/8).

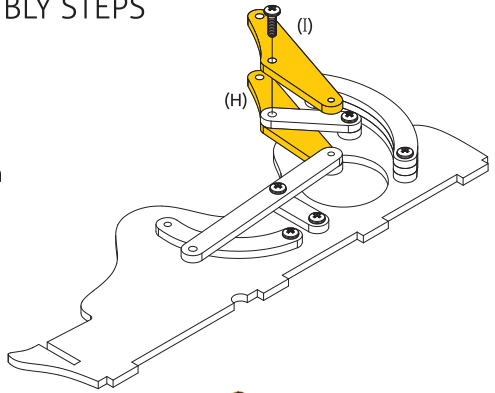

2.5

To ensure smooth operation, adjust the arms by scraping & smoothing the edges shown, using a sharp knife or sandpaper. Do this when removing them from the panel steps 1.6 and 1.7.

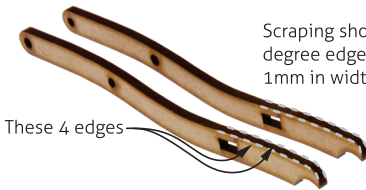

Scraping should result in 45 degree edges that are about 1mm in width.

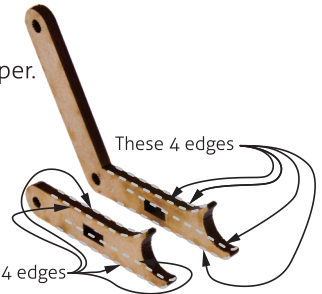

2.6

From panel 2, find the small lifter #1 (J), small lifter #2 (K), lifter spacer #1 (L), and spacer #2 (M). Assemble as shown, using a little white glue to keep the lifter spacer #1 (L) in place. Do *not* use white glue on the spacer #2 (M). Attach with 2x 3/8" screws.

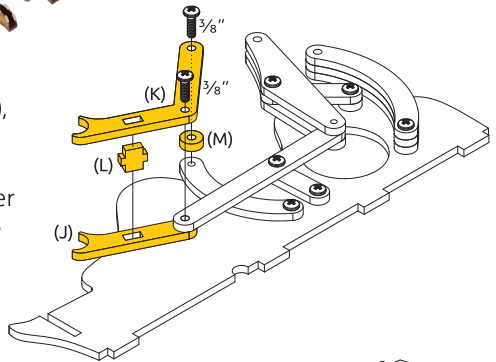

2.7

On Panel 3, remove large lifter #1 (N), large lifter #2 (O), lifter spacer #2 (P), and spacer #3 (Q). Assemble as shown, using a little white glue to keep the lifter spacer #2 (P) in place. Do *not* use glue on the spacer #3 (Q) (2x 5/8).

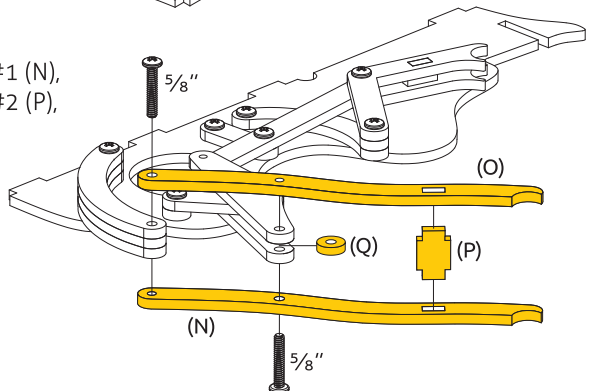

ASSEMBLY STEPS

- ⚠** Because the top screw of the "large lifter assembly" enters from the back side, make sure the screw ends flush with front of large lifter (O). If it extends past, it will interfere with the moving parts.



2.8

Use the #2 screw and washer to pin the triangles and large arm to any of the 4 holes of the plastic GMW motor connector wheel.

- ⚠** The washer has two sides, make sure the sharp edge is facing outwards, away from the arms.



rounded edge



sharp edge

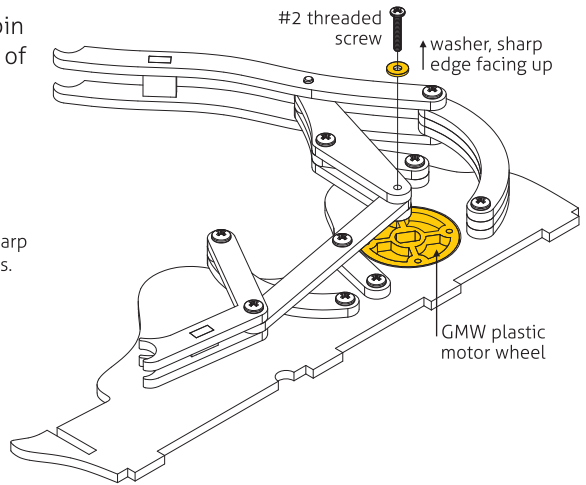

2.9

Attach the linkage base to the marble base (R) as shown, with the marble base logo-side up. Use a little white glue to keep it in place.

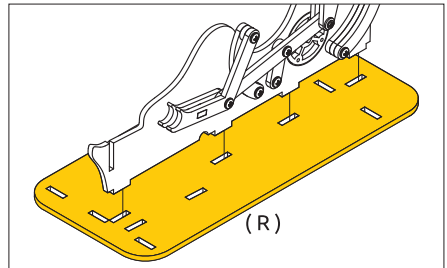

Step 3. Mounting the Motor

3.1

Align the mechanism so the GMPW wheel can receive the shaft of the GM3 motor. Hold the assembly together until the next step.

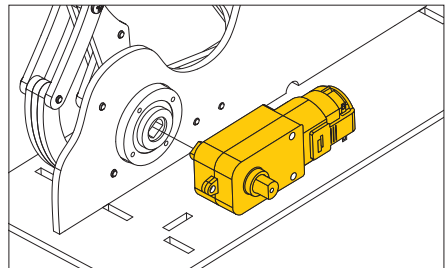

ASSEMBLY STEPS

3.2

From panel 4, remove motor mount (S) and rock it into position on the other side of the GM3 motor. Use some white glue to secure the tabs into the slots.

Side view:

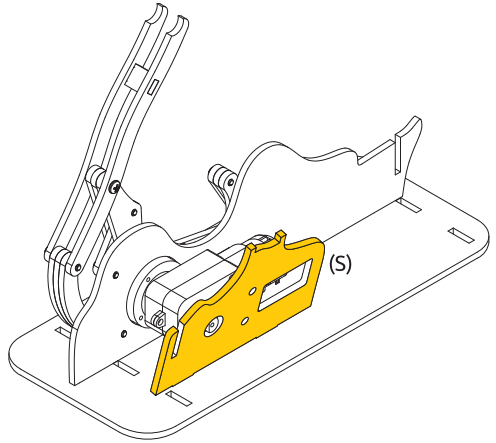
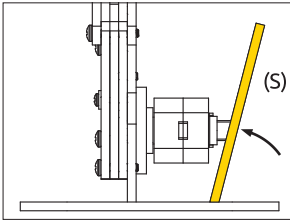

3.3

Secure the motor to the motor mount with 2 x #4 TFS (thread-forming screws). These have a heavier thread than the other screws.

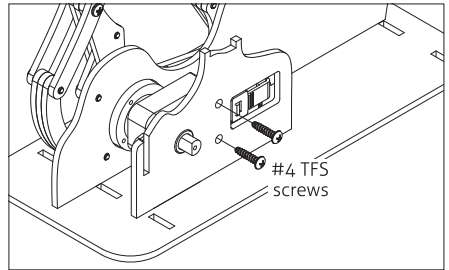

Step 4. Building the Towers

From panel 4 remove the Small tower (T), and from panel 2 the marble catch (U), and large tower (V). Slot them into the marble base, using a little white glue to keep everything in place.

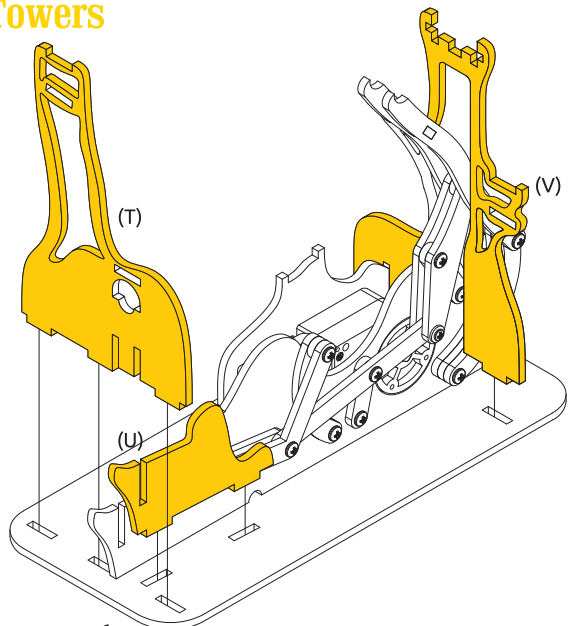

ASSEMBLY STEPS

Step 5. Attaching the Marble Tracks**5.1**

From panel 4, find and attach bottom track (W) as shown, using white glue at each tab connection. Start installation at the middle tabs, working out to the ends.

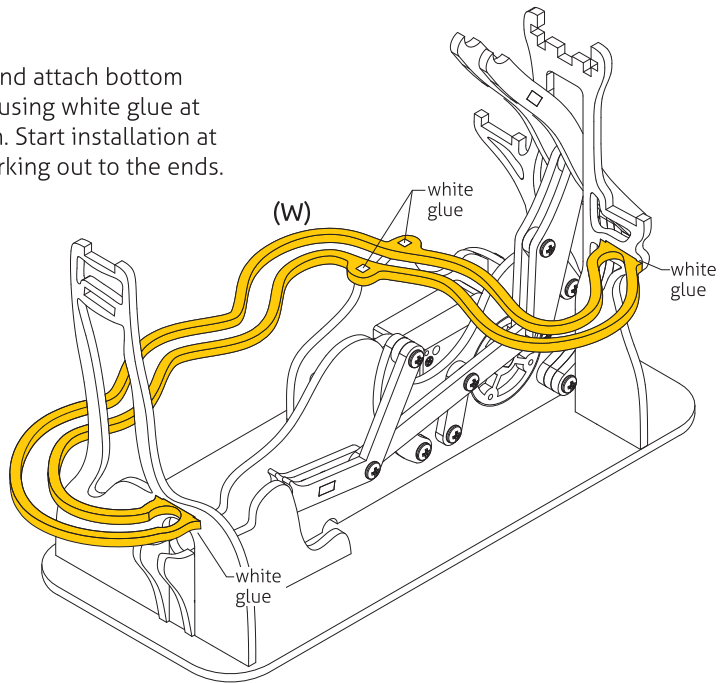
**5.2**

From panel 2 remove and attach the middle track (X) as shown, again using white glue to secure all of the tab connections.

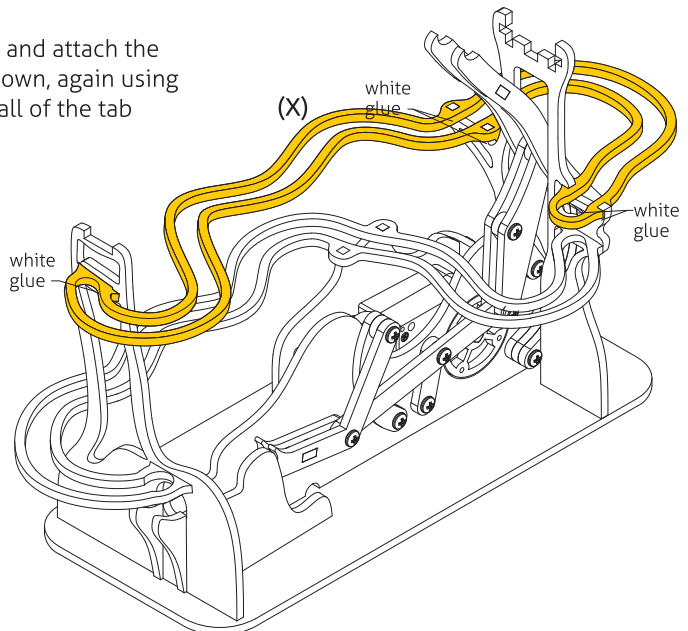

ASSEMBLY STEPS

5.3

From panel 4, remove the 2 x large receivers (Y) and 2 x small receivers (Z). Slot these all into the top of the Large tower (V) as shown.

Do *not* use any white glue until the end of the next step as these receivers need to be wiggled to help insert the top track.

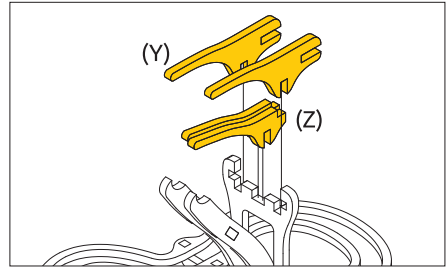

5.4

From panel 3, slot the top track (A2) into the receiver finger slots. When in place, use your white glue in these slots to hold everything in place.

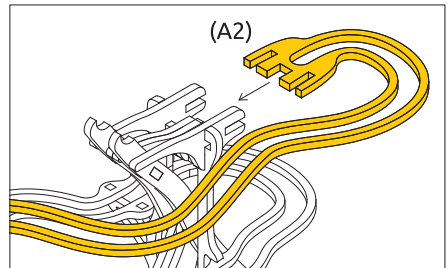

5.5

Attach the top track (A2) as shown. Use white glue to keep all of the tab areas secure. You can also add the optional rubber feet to the bottom of the Gravitrack at this time.

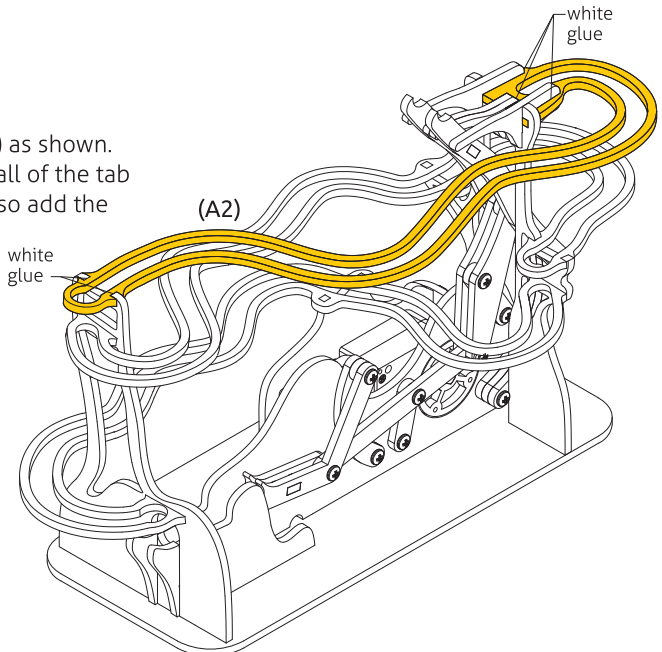

ASSEMBLY STEPS

Step 6. Installing the SolarEngine

6.1

The SolarEngine can be installed just behind the motor with the double-sided sticky-tape (DSST).

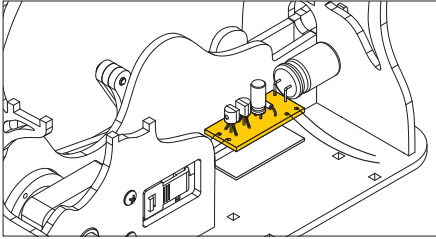

6.2

You can install the solar cell in several places. The solar cell mount parts from Panel 1 are configurable to suit the need.

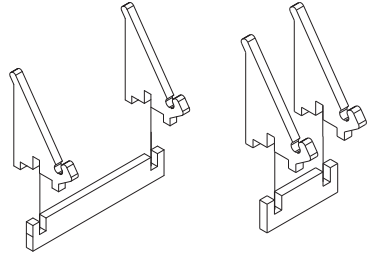

6.3

The GraviTrack solar cell locations are arranged to best expose the solar cell to light based on your requirement, being front (if on a shelf), back (as on a window-sill), or side (on a desk).

Top down view (all tracks removed in this view for better visibility):

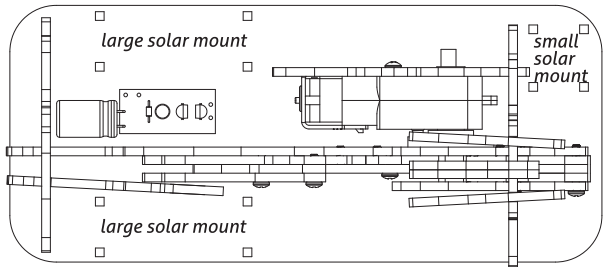

6.4

There are channels located on the GraviTrack for threading of the solar cell wires for best access.

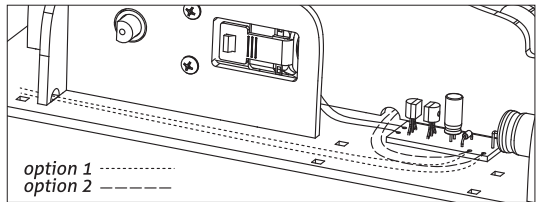

6.5

Solder the solar panel as shown. If you have already soldered your solar panel during the Solar Engine construction step, desolder it to fish the wires through the holes in step 6.4 and then resolder it.

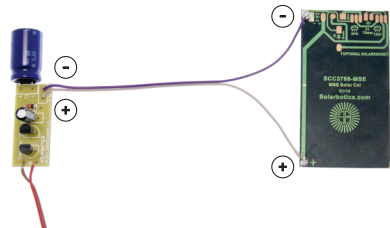

⚠ Test for successful wiring by holding the solarcell in sunlight or under a bright incandescent or halogen bulb. Correct operation is a counter-clockwise motor pulse every 3-6 seconds. Contact us if you can't troubleshoot the electronics.

DESIGNING YOUR OWN

Hey! Do you enjoy the GraviTrack and want to design your own version of the linkage? We built ours using David Rector's free linkage mechanism designer software found here: <http://blog.rectorsquid.com/linkage-mechanism-designer-and-simulator/>

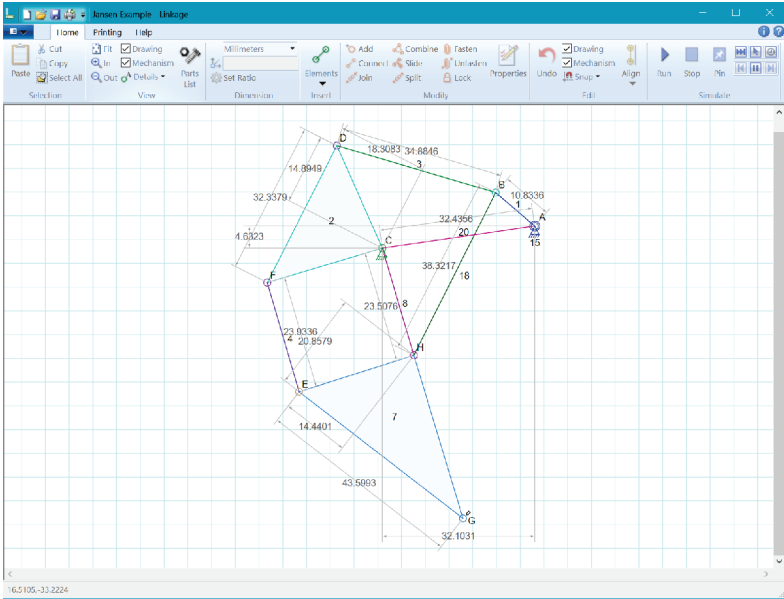

Although we have several CAD packages, we found his software to be extremely useful with a number of different options to create dynamic linkage systems with ease. One of the biggest benefits is that it allows you to export your designs in a DXF format for easy importing into your favorite vector cutting or CAD modeling software. We used a combination of Solidworks and CorelDraw to create the GraviTrack you've assembled today!

TROUBLESHOOTING

Linkage jams when the arms are attempting to pass the marble: Use a knife or other sharp edge to shave down the inside of the large lifter arms and the outside of the small lifter arms. See page 5, below step 2.5.

Linkage jams during linkage movement, or scraping noise can be heard: Adjust the screws a quarter turn at a time either tighter or looser until smooth, non-jamming movement has been obtained. Scraping noises are usually a sign that a screw is tightened too far and is poking out the back of the linkage pieces.

Marbles are falling off the track: The GraviTrack needs to be within $\sim 5^\circ$ of level for consistent operation. You may have to shim the surface of the GraviTrack to level it.

SolarEngine not working: See the suggestions below step 6.5.

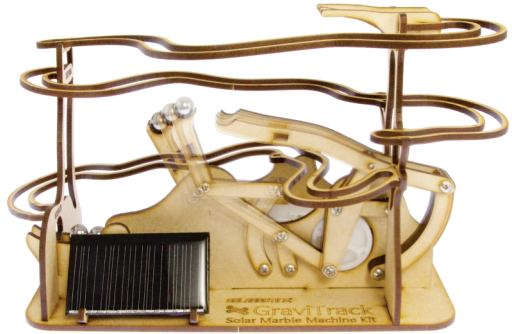

See it in action:
bit.ly/2y6Aqj0

Solarbotics "No Fear" Warranty

If damage occurs during construction, contact sales@solarbotics.com. We'll make sure you get the replacement parts to have a successful GraviTrack experience!

Visit us online for more info and cool stuff:

www.solarbotics.com

Questions or
comments?
Let us know!

✉ support@solarbotics.com
☎ 1-866-276-2687 (TOLL FREE)
MON-FRI, 9AM- 5PM MST

3740D - 11A Street NE
Suite 101
Calgary, Alberta T2E 6M6
Canada



This work is licensed under a Creative Commons
Attribution-ShareAlike 3.0 Unported License.

🇨🇦 Made in Canada



Solarbotics Ltd. is not responsible for any special, incidental, or consequential damages resulting from any breach of warranty, or under any legal theory, including lost profits, downtime, good-will, damage to or replacement of equipment or property, and any costs or recovering of any material or goods associated with the assembly or use of this product. Solarbotics Ltd. reserves the right to make substitutions and changes to this product without prior notice. Keep out of reach of children. Product contains small parts, even when assembled, that might be a choking hazard for children under five. © 2017 Solarbotics Ltd. All rights reserved. Parts, quantities, features and specifications are subject to change without notice. All other trademarks are property of their respective owners. "SOLARBOTICS" is a trademark of Solarbotics Ltd. Reg. CIPO / USPTO.