

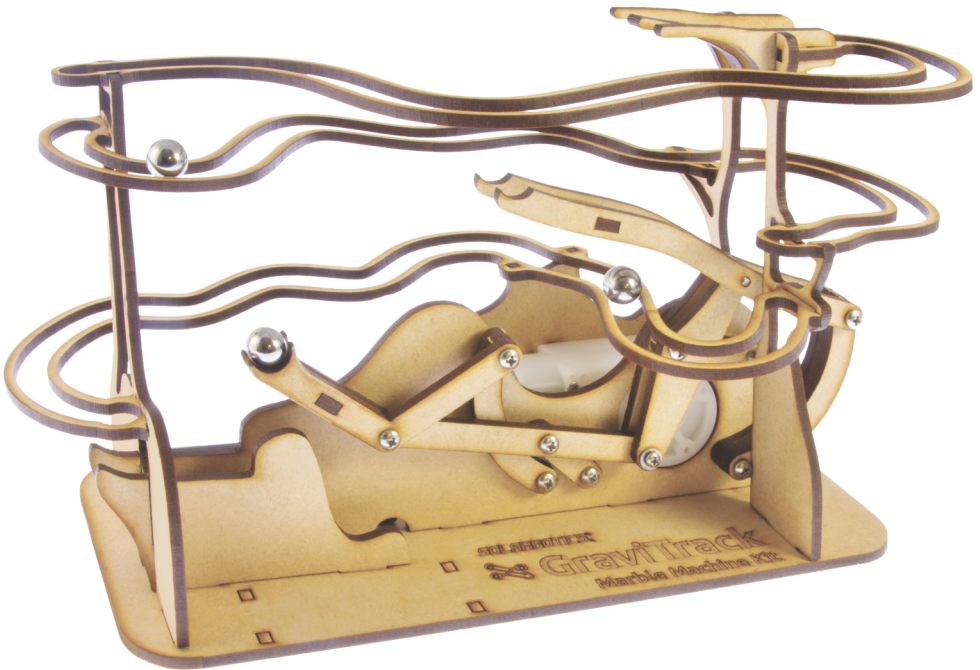

# GraviTrack Marble Machine Kit

This elegant battery-powered mechanism lifts & passes the marble from one hand to the other.



Beginner skill level - ages 12+



Basic tools required  
(no soldering)



2 x AAA batteries required  
(not included)



2 hours build time



[www.solarbotics.com](http://www.solarbotics.com) 1-866-276-2687

[solarbotics.com/products/60410/](http://solarbotics.com/products/60410/)  
Document revision: October 6 2017

## NOTES

## PARTS LIST

1 x Set of laser-cut wooden parts

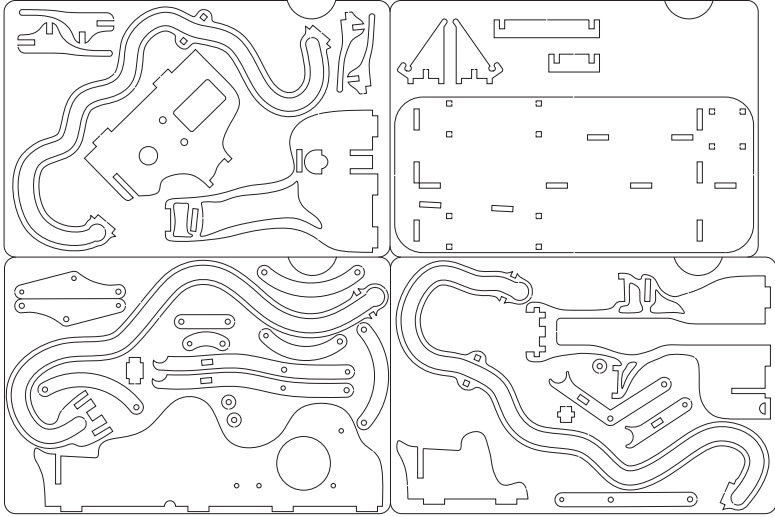

1 x GMW Motor mount

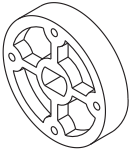

1 x GM3 Motor + battery pack

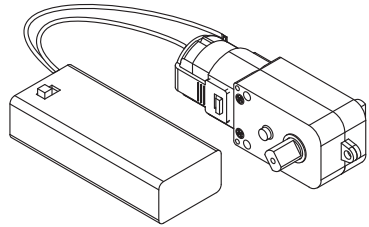

4 x 0.375" steel marbles

1 x #2 washer



\*parts to scale

3 x 1/4"  
4-40 screw



2 x 1/2" #4  
TF screw

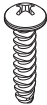

1 x 1/2"  
4-40 screw



2 x 5/8"  
4-40 screw

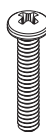

3 x 3/8"  
4-40 screw



1 x 1/2"  
#2 screw



## TOOLS REQUIRED

Philips screw driver  
White glue  
File/exacto knife

## ASSEMBLY STEPS

**Step 1. Assembling the Linkage**

All the laser cut parts are labeled and marked per panel. It's now the simple process of find, prepare, and assemble!

**1.1**

Panel 3 has your linkage base (A). Locate the small curve (B), small arm (C), and 3 x large curves (D). Use the screwdriver to remove any sticking cutouts.

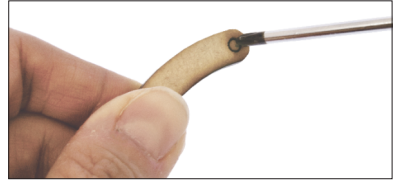
**1.2**

Assemble the pieces to the linkage base as shown. Make sure the larger of the two holes of the small arm (C) is used to attach it to the base (2x 1/4" screw, 1x 1/2" screw).

**⚠** Tighten the screws so all pieces can move without friction but stay flat against linkage base. So make them tight but not too tight so they can't move smoothly.

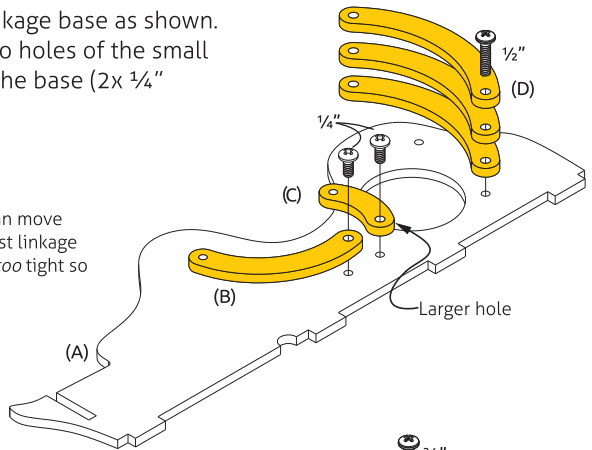
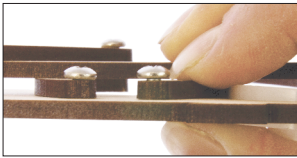
**1.3**

Assemble spacer #1 (F), and medium arm (G) and from Panel 3, and the large arm (E) from panel 2. Remove any cutouts and attach to the linkage base as shown (1x 1/4" screw, 1x 3/8" screw).

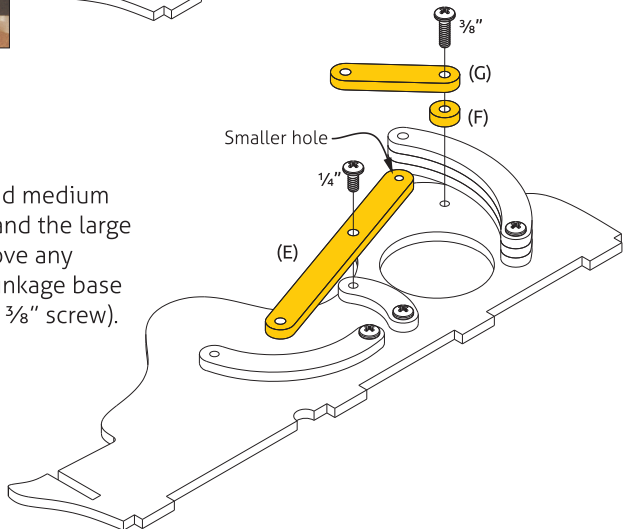



## ASSEMBLY STEPS

### 1.4

From panel 3, get Triangle #1 (H) and Triangle #2 (I), and attach to the linkage base as shown. Install Triangle #1 (H) on the bottom (1x 3/8).

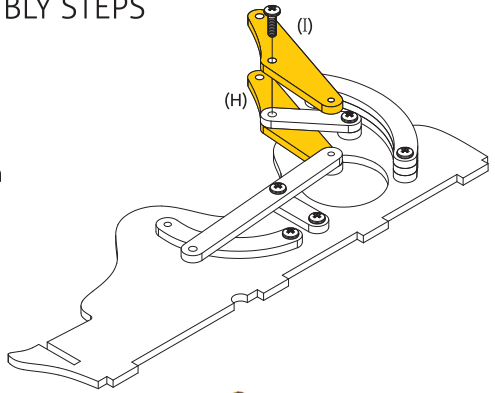

### 1.5

To ensure smooth operation, adjust the arms by scraping & smoothing the edges shown, using a sharp knife or sandpaper. Do this when removing them from the panel steps 1.6 and 1.7.

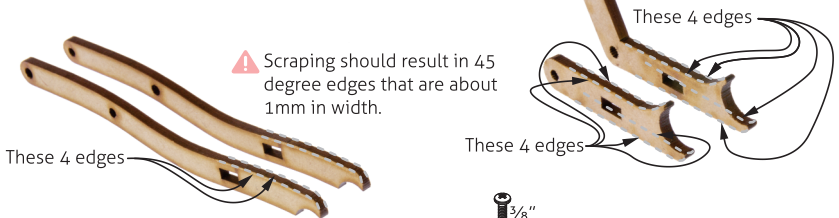

### 1.6

From panel 2, find the small lifter #1 (J), small lifter #2 (K), lifter spacer #1 (L), and spacer #2 (M). Assemble as shown, using a little white glue to keep the lifter spacer #1 (L) in place. Do *not* use white glue on the spacer #2 (M). Attach with 2x 3/8" screws.

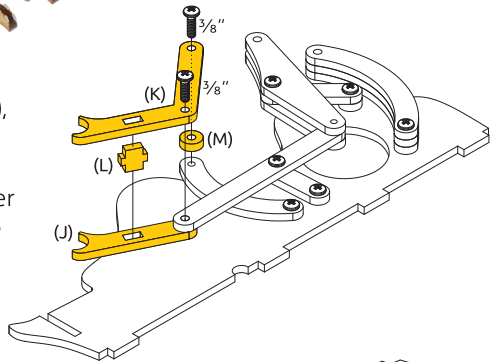

### 1.7

On Panel 3, remove large lifter #1 (N), large lifter #2 (O), lifter spacer #2 (P), and spacer #3 (Q). Assemble as shown, using a little white glue to keep the lifter spacer #2 (P) in place. Do *not* use glue on the spacer #3 (Q) (2x 5/8).

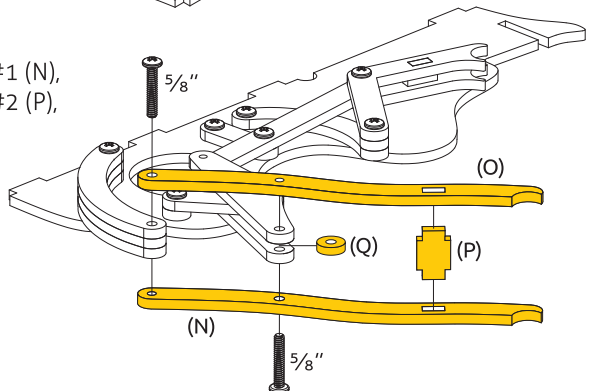

## ASSEMBLY STEPS

- ⚠** Because the top screw of the "large lifter assembly" enters from the back side, make sure the screw ends flush with front of large lifter (O). If it extends past, it will interfere with the moving parts.

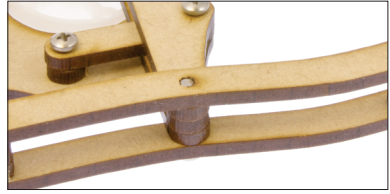

### 1.8

Use the #2 screw and washer to pin the triangles and large arm to any of the 4 holes of the plastic GMW motor connector wheel.

- ⚠** The washer has two sides, make sure the sharp edge is facing outwards, away from the arms.



rounded edge



sharp edge

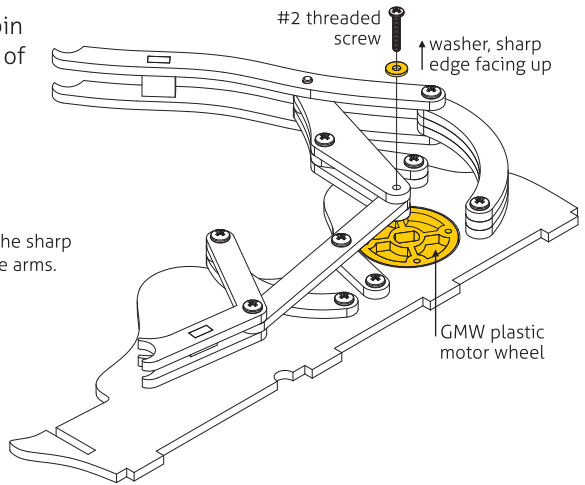

### 1.9

Attach the linkage base to the marble base (R) as shown, with the marble base logo-side up. Use a little white glue to keep it in place.

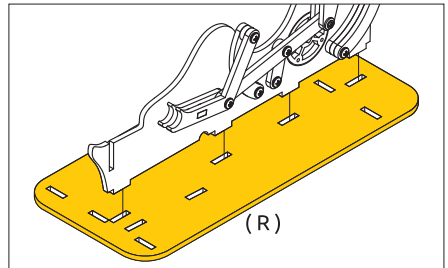

## Step 2. Mounting the Motor

### 2.1

Align the mechanism so the GMPW wheel can receive the shaft of the GM3 motor. Hold the assembly together until the next step.

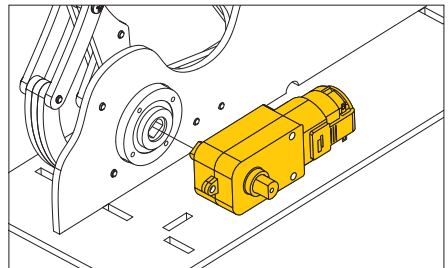

## ASSEMBLY STEPS

## 2.2

From panel 4, remove motor mount (S) and rock it into position on the other side of the GM3 motor. Use some white glue to secure the tabs into the slots.

Side view:

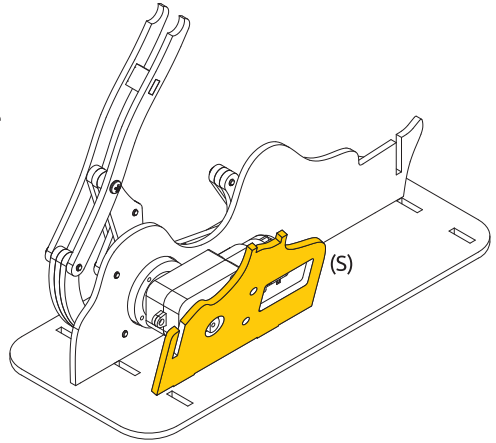
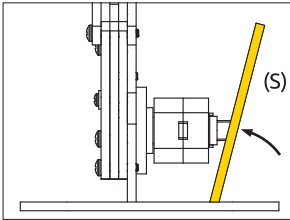

## 2.3

Secure the motor to the motor mount with 2 x #4 TFS (thread-forming screws). These have a heavier thread than the other screws.

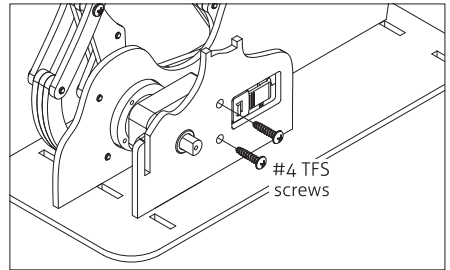

## Step 3. Building the Towers

From panel 4 remove the small tower (T), and from panel 2 the marble catch (U), and large tower (V). Slot them into the marble base, using a little white glue to keep everything in place.

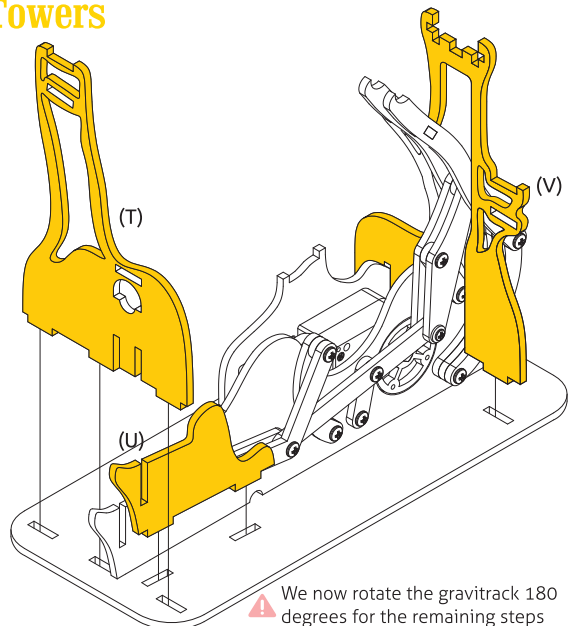

⚠ We now rotate the gravitrack 180 degrees for the remaining steps

## ASSEMBLY STEPS

**Step 4. Attaching the Marble Tracks****4.1**

From panel 4, find and attach bottom track (W) as shown, using white glue at each tab connection. Start installation at the middle tabs, working out to the ends.

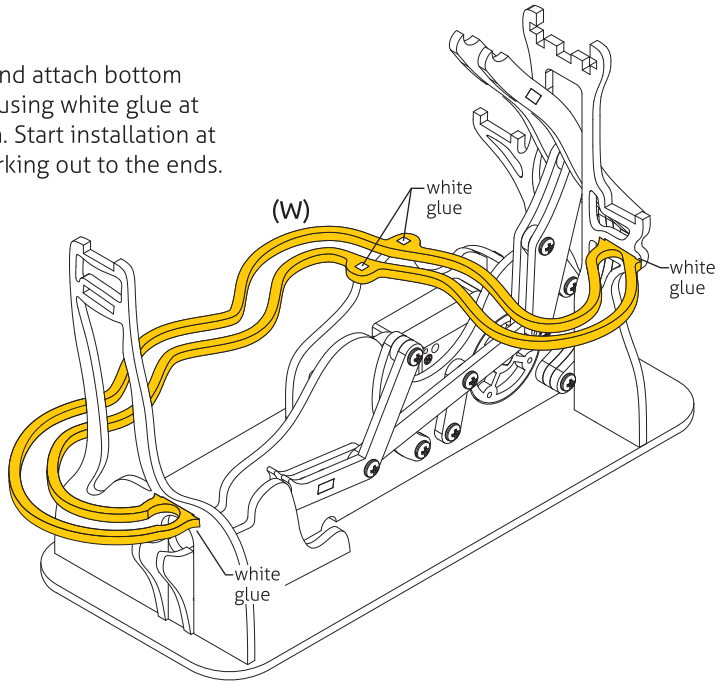
**4.2**

From panel 2 remove and attach the middle track (X) as shown, again using white glue to secure all of the tab connections.

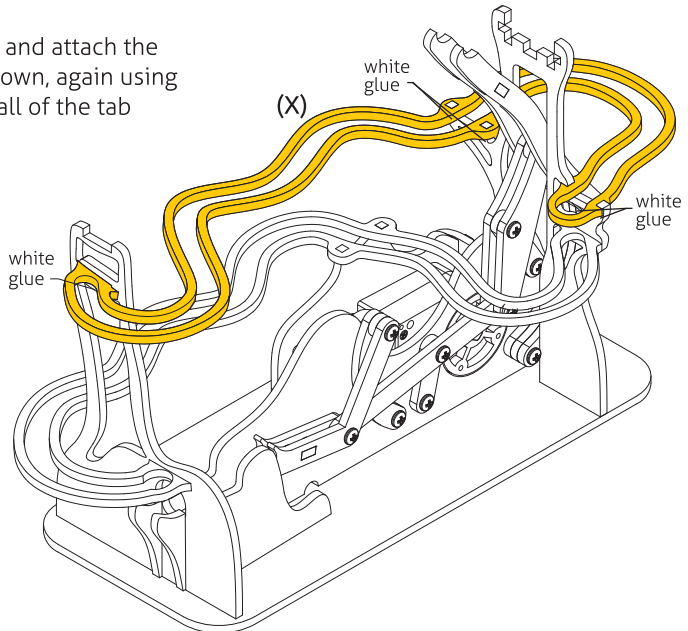

## ASSEMBLY STEPS

## 4.3

From panel 4, remove the 2 x large receivers (Y) and 2 x small receivers (Z). Slot these all into the top of the Large tower (V) as shown.

Do *not* use any white glue until the end of the next step as these receivers need to be wiggled to help insert the top track.

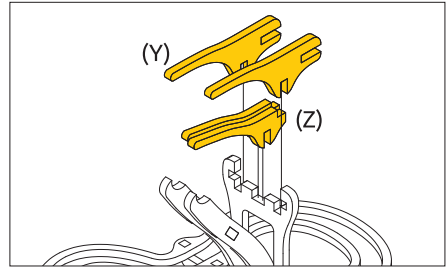

## 4.4

From panel 3, slot the top track (A2) into the receiver finger slots. When in place, use your white glue in these slots to hold everything in place.

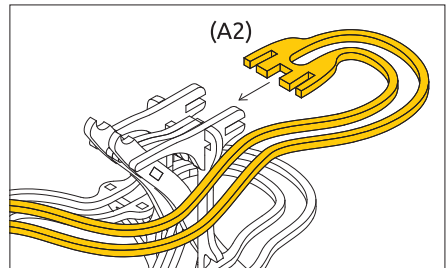

## 4.5

Attach the top track (A2) as shown. Use white glue to keep all of the tab areas secure. You can also add the optional rubber feet to the bottom of the Gravitrack at this time.

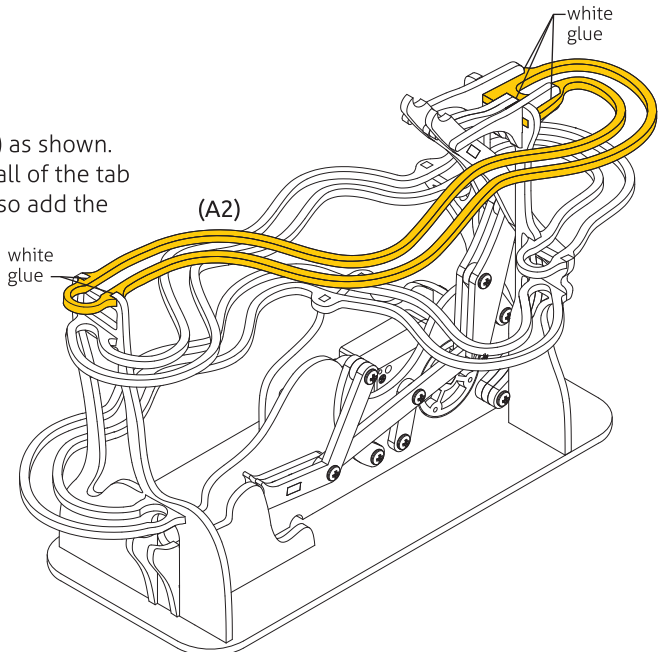

## DESIGNING YOUR OWN

Hey! Do you enjoy the GraviTrack and want to design your own version of the linkage? We built ours using David Rector's free linkage mechanism designer software found here:

<http://blog.rectorsquid.com/linkage-mechanism-designer-and-simulator/>

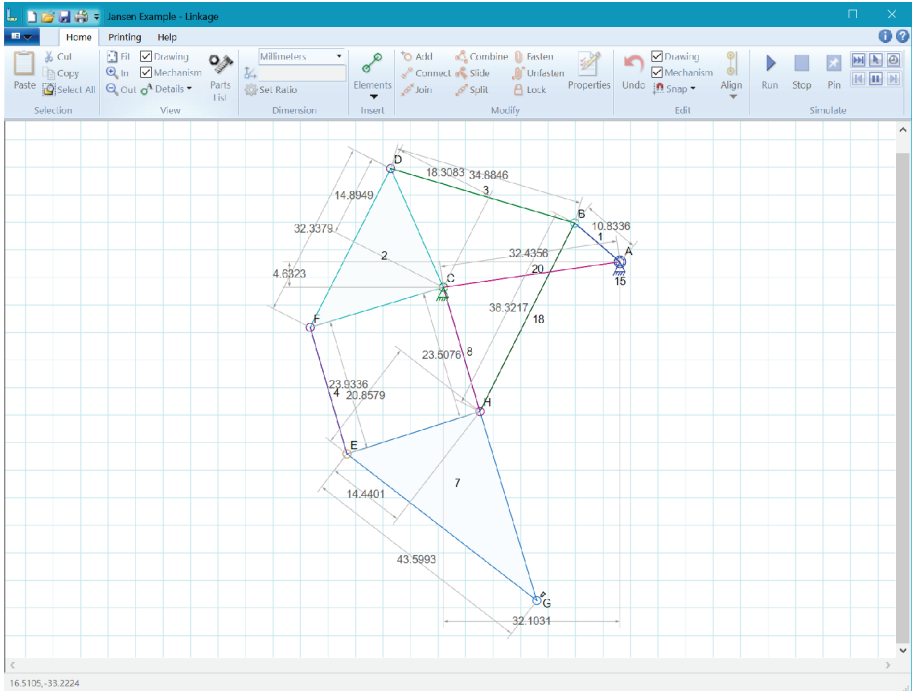

Although we have several CAD packages, we found his software to be extremely useful with a number of different options to create dynamic linkage systems with ease. One of the biggest benefits is that it allows you to export your designs in a DXF format for easy importing into your favorite vector cutting or CAD modeling software. We used a combination of Solidworks and CorelDraw to create the GraviTrack you've assembled today!

## TROUBLESHOOTING

**If your Marble Machine isn't fully functional, check this troubleshooting list.**

**Linkage jams when the arms are attempting to pass the marble try this:**

Use a knife or other sharp edge to shave down the inside of the large lifter arms and the outside of the small lifter arms. See page 5, below step 2.4.

**Linkage jams at other points during linkage movement or scraping noise can be heard:**

We recommend adjusting the screws one quarter turn at a time either tighter or looser until smooth, non-jamming movement has been obtained. Scraping noises are usually a sign that a screw is tightened too far and is poking out the back of the linkage pieces.

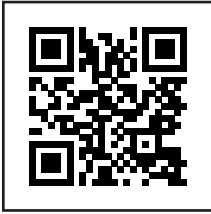

See it in action:  
[bit.ly/2xKEp30](http://bit.ly/2xKEp30)

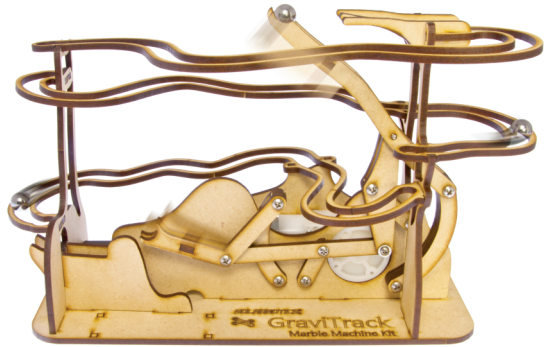

---

## Solarbotics "No Fear" Warranty

If damage occurs during construction, contact [sales@solarbotics.com](mailto:sales@solarbotics.com). We'll make sure you get the replacement parts to have a successful GraviTrack experience!

---

Visit us online for more info and cool stuff:

[www.solarbotics.com](http://www.solarbotics.com)

Questions or  
comments?  
Let us know!

✉ [support@solarbotics.com](mailto:support@solarbotics.com)  
☎ 1-866-276-2687 (TOLL FREE)  
MON-FRI, 9AM- 5PM MST

3740D - 11A Street NE  
Suite 101  
Calgary, Alberta T2E 6M6  
Canada



This work is licensed under a Creative Commons  
Attribution-ShareAlike 3.0 Unported License.

 Made in Canada



Solarbotics Ltd. is not responsible for any special, incidental, or consequential damages resulting from any breach of warranty, or under any legal theory, including lost profits, downtime, good-will, damage to or replacement of equipment or property, and any costs or recovering of any material or goods associated with the assembly or use of this product. Solarbotics Ltd. reserves the right to make substitutions and changes to this product without prior notice. Keep out of reach of children. Product contains small parts, even when assembled, that might be a choking hazard for children under five. © 2017 Solarbotics Ltd. All rights reserved. Parts, quantities, features and specifications are subject to change without notice. All other trademarks are property of their respective owners. "SOLARBOTICS" is a trademark of Solarbotics Ltd. Reg. CIPO / USPTO.