

The Solarbotics Northern Lights LED / Controller Bundle

Combining the *SB-FireFly* and the *Star Controller* to create a HUGE RGB LED element with configurable color patterns!

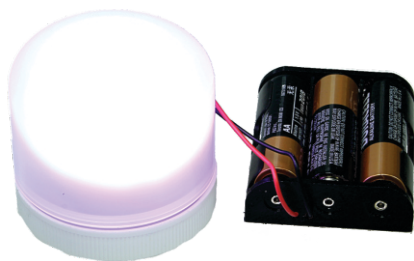

Parts Included:

- 60140 SB-FireFly kit
- 60160 Star Controller RGB LED kit
- 52242 2.1mm barrel jack/plug pair
- 17020 3AA battery holder
- 0.1 μ F Capacitor
- 8025 diffusion container
- Double-sided tape
- 5-conductor wire

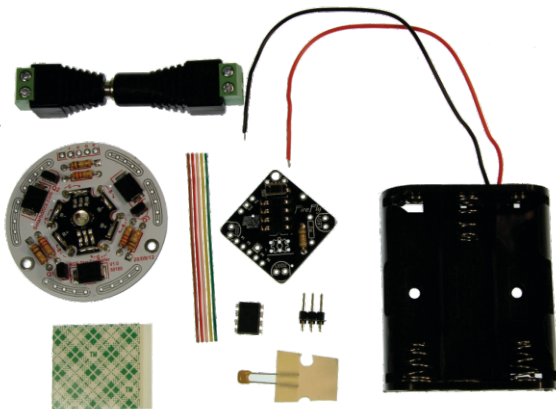

Step 1 - Build the kits, but only so far:

Build the **SB-FireFly** up to step 3, and the **Star Controller** up to Step 7c. Now prepare them to be merged!

Solder in the 0.1 μ F capacitor across the 'G' and 'V' pads at the top of the Firefly PCB, which will make the Firefly happier to work with the Star Controller.

Solder in the 2x3 pin header in place over the "Open Hardware" logo. We'll use some of these programming pins to run power through to the Star Controller.

Install the microcontroller with the dot lining up with the notch in the chip carrier (just as pictured in the SB-FireFly manual).

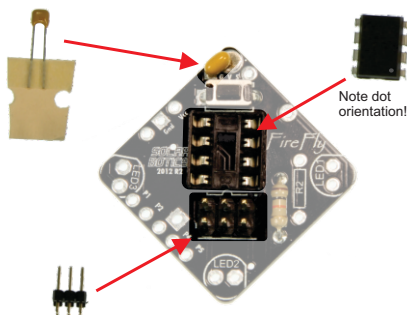

The Solarbotics Northern Lights LED / Controller Bundle

Step 2 - Prepare the Wire: Split the ends of the ribbon cable, and strip the insulation off the ends.

Next, cut approximately half of the battery pack wire, and again, strip *all* the ends for soldering.

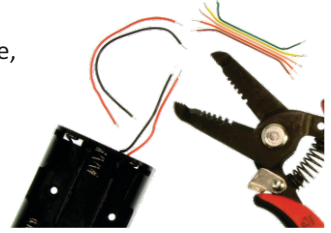

Step 3 - Firefly Ribbon Cable: Take a close look at your ribbon cable. Three of the wires will send the color signals, and the other two send the power. To keep wiring identification simpler, let's try to identify a side being "Power". Find one side of the cable with either a **red** wire or the **darkest** wire color, so we can use red to identify '+', or the darkest wire to identify '-'.

Solder the ribbon cable to the SB-Firefly, starting with these power wires to the 'Gnd' and 'Vcc' pads. Install the wires from the components side - we're trying to keep the solder-side of the Firefly flat for easy mounting later.

Continue soldering the ribbon wires to pads **P0**, **P1**, **P4**.

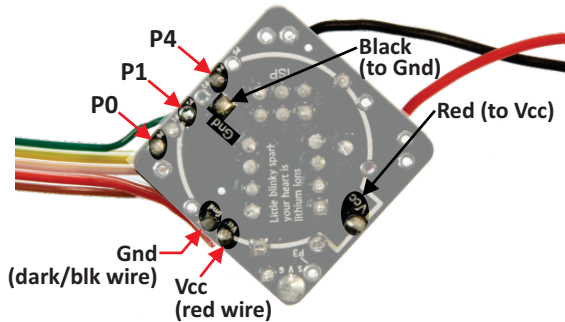

Step 4 - Battery Wires:

Solder on the snipped red and black wires to the Vcc (red) & Gnd (black) pads, from the component-side of the circuit board.

Step 5 - Connecting the two!: Solder the other end of the ribbon cable to the Star Controller. The only super-important ones are the 'Gnd' and 'Vcc' lines, but try to match our color signal lines where P0 = Red, P1 = Green, and P4 = Blue. Otherwise, you can easily redefined the pin definitions in the Firefly code.

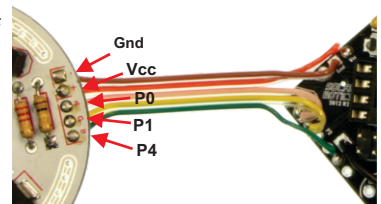

Step 6 - Power Plug: Screw the *stripped wires* into the end of the plug, red to '+' and black to '-'.

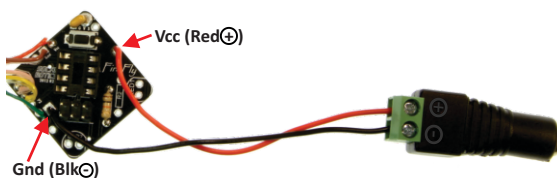

Step 7 - Power Jack: Screw the battery pack's *stripped wires* into the end of the jack, red to '+' and black to '-'. NO, don't plug them together... yet...

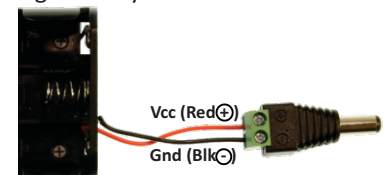

The Solarbotics Northern Lights LED / Controller Bundle

Step 8 - Batteries and

Sticky Tape:

Super easy stuff - install the 3 'AA' batteries. Then peel & stick one side of the sticky tape to the bottom of the SB-Firefly board.

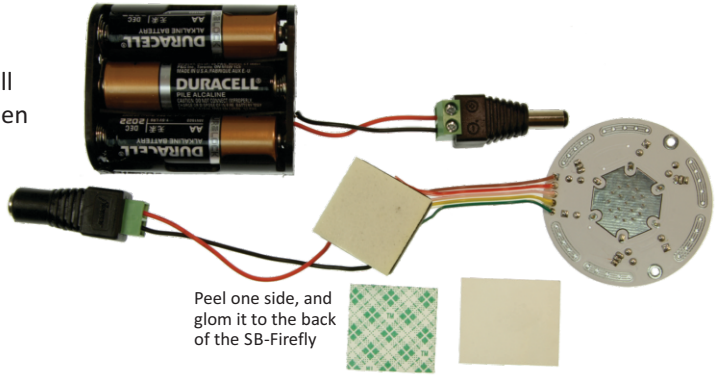

Peel one side, and glom it to the back of the SB-Firefly

Step 9 - Glom One to the Other: Peel off the other film from the sticky tape and glom the SB-Firefly square to the bottom of the Star Controller board, so the ribbon cable bundles up neatly beside the Attiny85 chip.

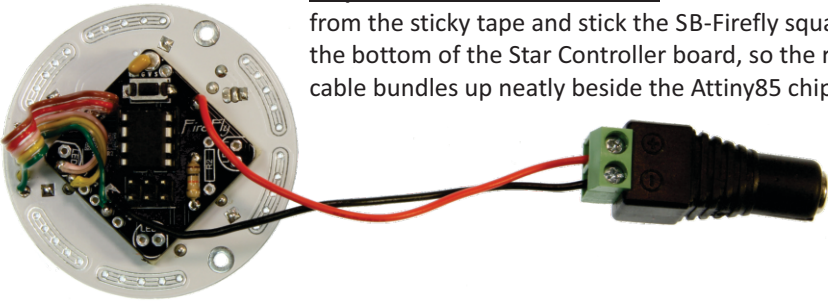

Step 10 - Testing It (or "Mommy, why can't I see your face anymore?"):

WARNING: WAIT - DO NOT JUST PLUG IT IN! Why? Because this is a dazzlingly bright, tiny-point light source that will leave substantial after-images temporarily burned to your retina. *Learn* from our mistakes. This is experience talking. Now repeat after me... I will NOT look directly at the LED!.. say it again... Ok good.

Plug the barrel connectors together and see if everything lights up. Push the button on the SB-FireFly to toggle through all the modes and speeds.

When the LED goes out the Firefly is in low power sleep mode.

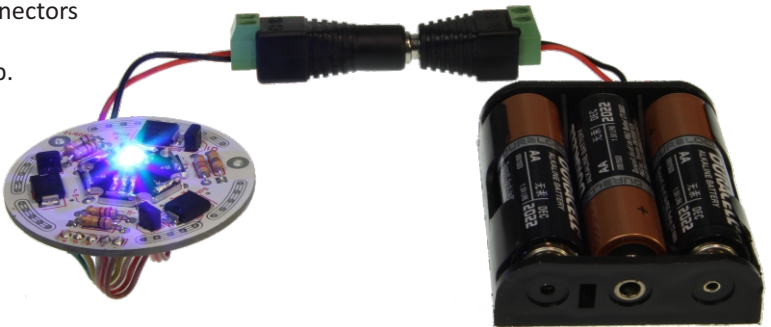

You stared at it for too long, didn't you? Yeah, it's hard to resist. It'll be much easier to enjoy after you have it all mounted in the diffusion container! Go have a drink and wait for your vision to come back...

The Solarbotics Northern Lights LED / Controller Bundle

Step 11 - Mounting: Drop the unit into the diffusion container, and screw it shut. NOW you can stare at it.

You *can* cut a slot into the cap to free the wiring, but we find the plastic give enough we can simply screw it shut.

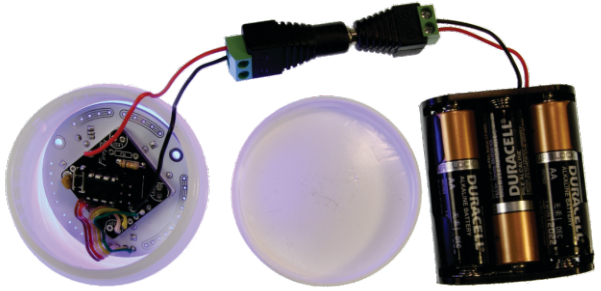

Select your favorite display mode, and cap it shut. The SB-Firefly remembers this setting, so will restart with it every time you plug in the battery pack, which will run the bundle for approximately 3 days on a fresh set of quality alkaline cells.

Remember - Flashing amber is for emergency vehicles only. Flashing red & blue is only for law enforcement. Use this bundle on your vehicle *at your own discretion & risk*, because it does a pretty good job at looking official!

An official TARDIS lamp just blinks white, but that doesn't mean you couldn't make your own TARDIS with an RGB lamp...



This design is released under a Creative Commons, Attribution, Share-alike license 3.0. Use it, change it, and share it!

Visit us online for more info and cool stuff:



Solarbotics Ltd.
3740D - 11A Street NE, Suite 101
Calgary, Alberta T2E 6M6
Canada

Toll Free: 1-866-276-2687
International: +1 (403) 232-6268
Fax: +1 (403) 226-3741

